

GLOBAL

OS 7700 P

Ornamental stitching machine

**INSTRUCTION / OPERATING MANUAL
PARTS MANUAL**

WWW.GLOBALSEW.COM

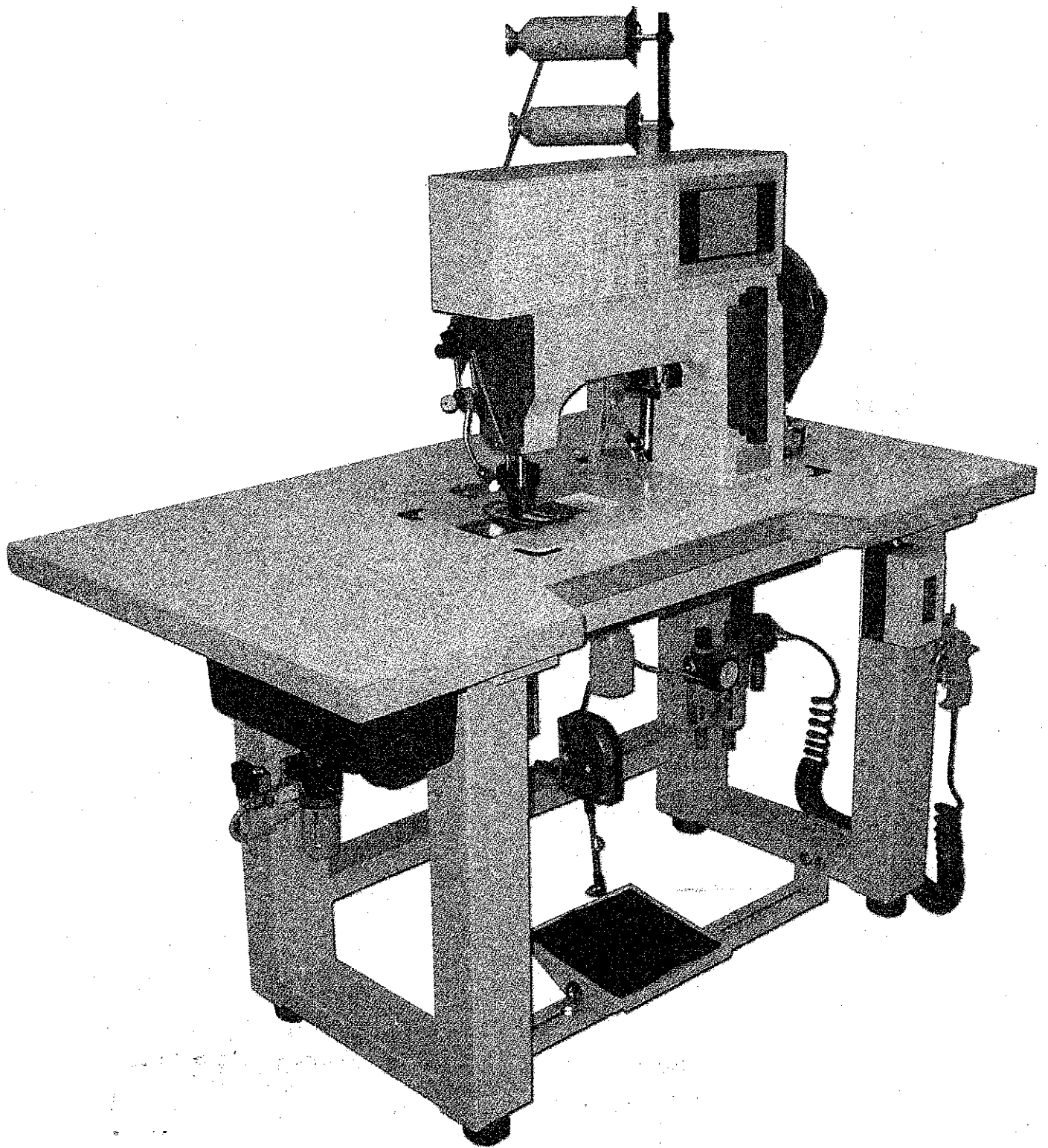

From the Library of Superior Sewing Machine & Supply LLC

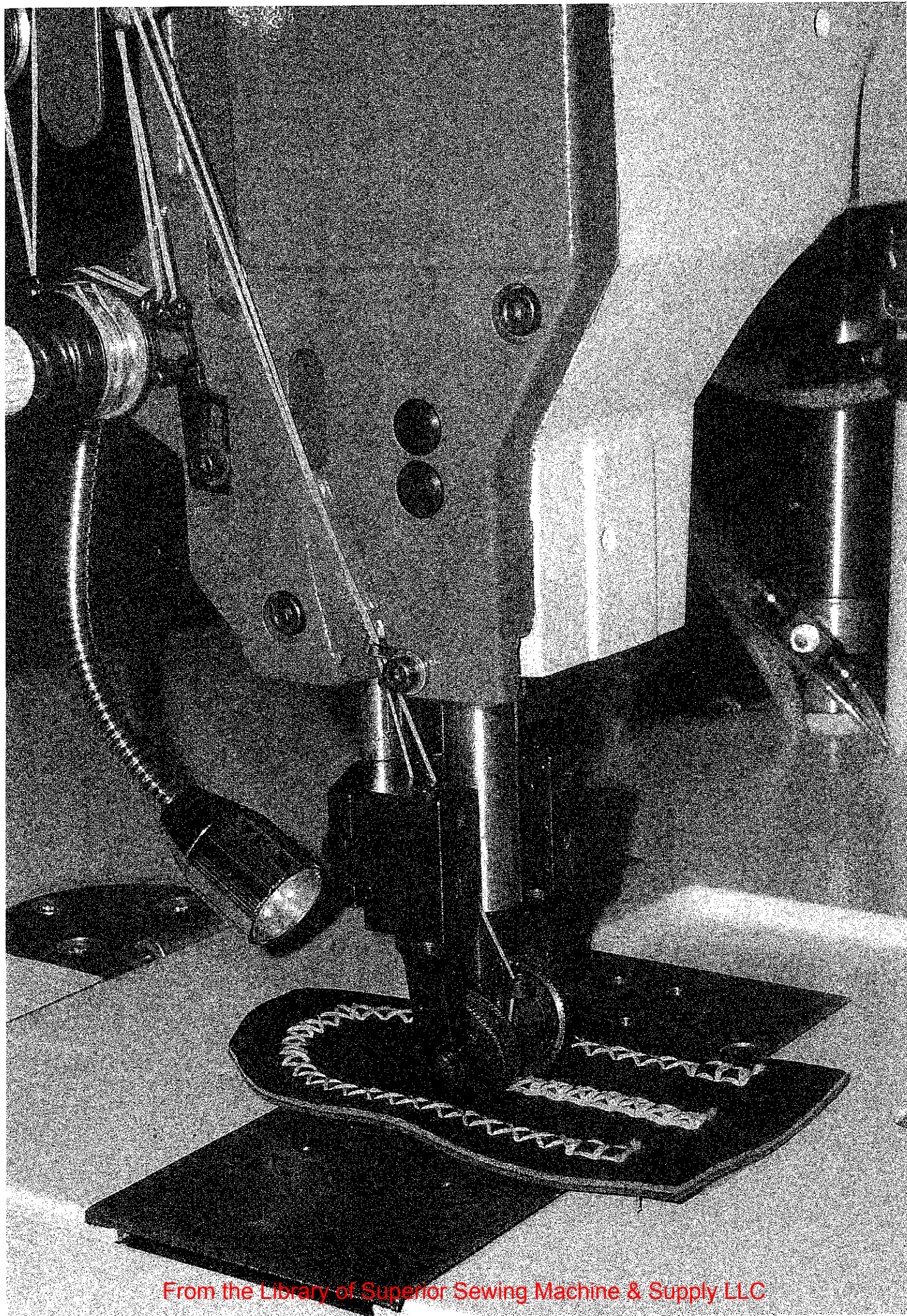

From the Library of Superior Sewing Machine & Supply LLC

GLOBAL OS 7700 P

NEEDLE SHAFT ROTATE MECHANISM

1	MZC-0001	ASSEMBLY TABLE
2	MZC-0002	TABLE ASSEMBLY SCREW
3	MZC-0003	RIGHT SLEDGE SEAT
4	MZC-0004	SLEDGE SEAT ASSEMBLY SCREW
5	MZC-0005	LEFT SLEDGE SEAT
6	MZC-0006	UPPER NEEDLE SHAFT THIMBLE
7	MZC-0007	NEEDLE SHAFT
8	MZC-0008	NEEDLE SHAFT HOLDING
9	MZC-0009	NEEDLE SHAFT HOLDING SCREW
10	MZC-0010	NEEDLE SHAFT BRACELET
11	MZC-0011	NEEDLE BAR CONNECTED ROD
12	MZC-0012	ROTARY DRIVE
13	MZC-0013	ROTARY DRIVE CONNECTION SHAFT
14	MZC-0014	ROTARY DRIVE CONNECTION SHAFT NOZZLE
15	MZC-0015	ROTARY DRIVE ASSEMBLY SCREW
16	MZC-0016	NEEDLE SHAFT BAR
17	MZC-0017	NEEDLE SHAFT CLAMP
18	MZC-0018	NEEDLE SHAFT CLAMP SCREW
19	MZC-0019	NEEDLE SHAFT WASHER
20	MZC-0020	NEEDLE SHAFT BAR HOLDING
21	MZC-0021	NEEDLE SHAFT WASHER
22	MZC-0022	NEEDLE SHAFT BAR WASHER SCREW
23	MZC-0023	BOTTOM NEEDLE SHAFT THIMBLE
24	MZC-0024	NEEDLE SHAFT CLAMP PIN

(NEEDLE SHAFT ROTATE MECHANISM)

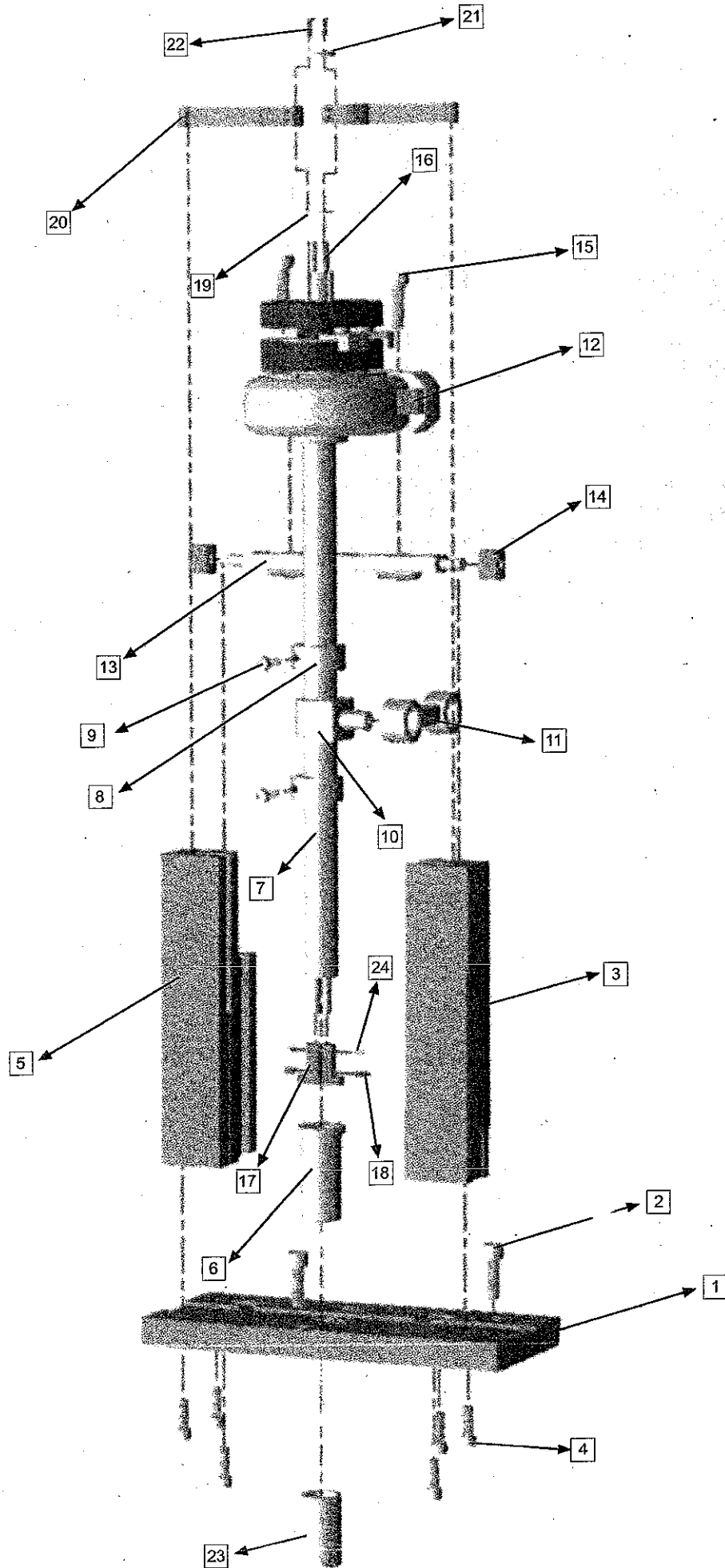

GO BACK MECHANISM

1	MZC-0025	ROTARY DRIVE
2	MZC-0026	ROTARY DRIVE ASSEMBLY SCREW
3	MZC-0027	ROTARY DRIVE WEDGE
4	MZC-0028	ECCENTRIC CONNECTION SHAFT
5	MZC-0029	ECCENTRIC CONNECTION SHAFT SCREW
6	MZC-0030	WASHER
7	MZC-0031	ROTARY DRIVE CONNECTION SEAT
8	MZC-0032	ECCENTRIC NOZZLE BEARING
9	MZC-0033	ECCENTRIC NOZZLE
10	MZC-0034	ECCENTRIC NOZZLE ASSEMBLY SCREW
11	MZC-0035	ECCENTRIC TONGS
12	MZC-0036	ECCENTRIC NOZZLE SCREW NUT
13	MZC-0037	ECCENTRIC
14	MZC-0038	ECCENTRIC WASHER
15	MZC-0039	GO-BACK SHAFT

(GO BACK MECHANISM)

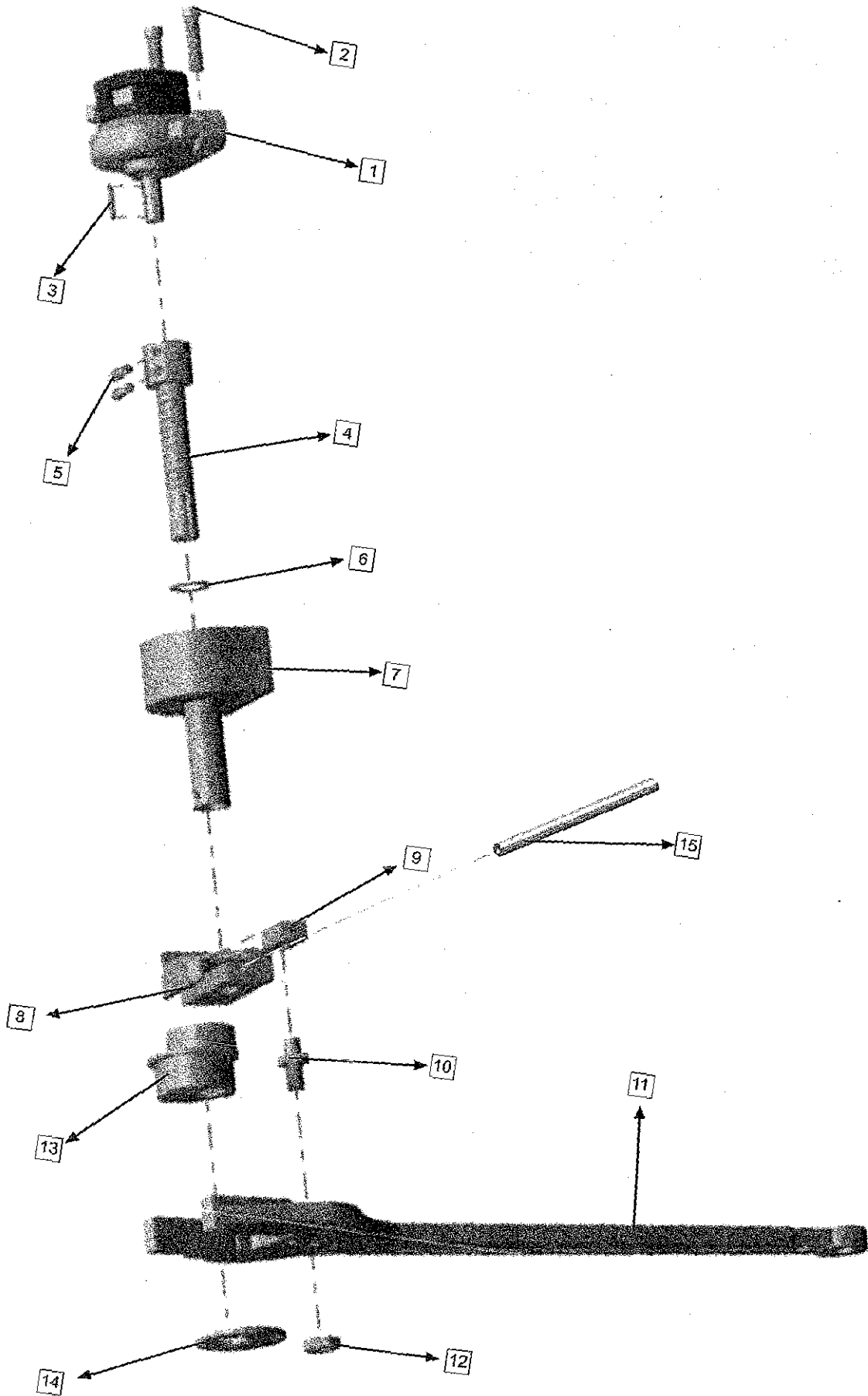

PACE ADJUSTMENT MECHANISM

1	MZC-0039	PACE ADJUSTMENT HOLDING
2	MZC-0040	PACE ADJUSTMENT HOLDING PIN
3	MZC-0041	PACE ADJUSTMENT HOLDING SPRING
4	MZC-0042	PACE ADJUSTMENT SLEDGE
5	MZC-0043	PACE ADJUSTMENT SEAT
6	MZC-0044	CHOCK HOLDING
7	MZC-0045	PACE ADJUSTMENT HOLDING NUT

(PACE ADJUSTMENT MECHANISM)

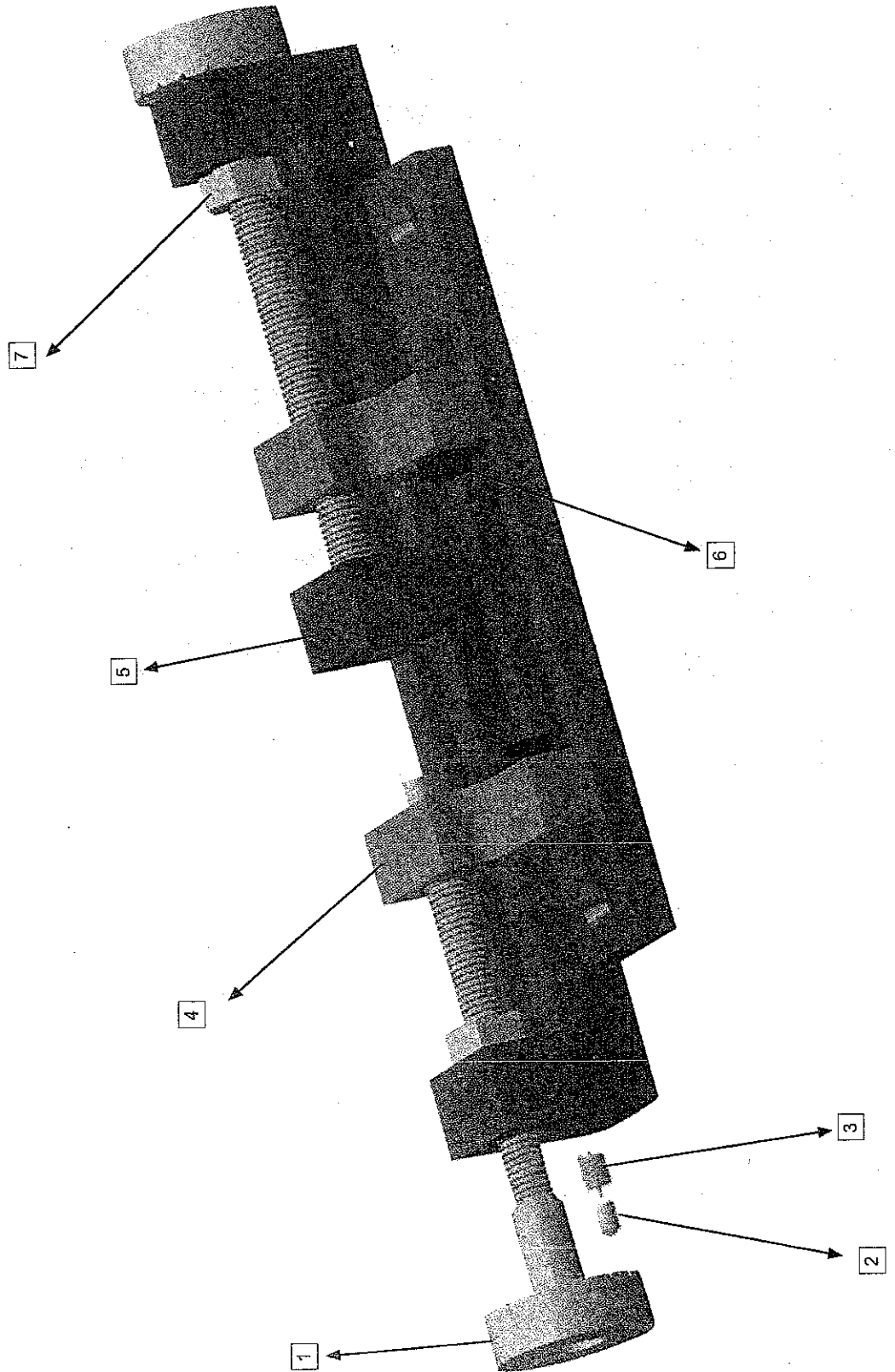

PRESS AND HAND WHEEL SYSTEM

1	MZC-0001	ASSEMBLY TABLE
2	MZC-0046	PRESS SCREW
3	MZC-0002	SCREW
4	MZC-0047	FOOT PRESS SHAFT
5	MZC-0048	FOOT PRESS SPRING
6	MZC-0049	FOOT SHAFT HOLDING
7	MZC-0050	SCREW
8	MZC-0051	HAND WHEEL SCREW
9	MZC-0052	HAND WHEEL
10	MZC-0053	HAND WHEEL MAIN SEAT
11	MZC-0054	SCREW
12	MZC-0055	GUIDE (FOR THIN MATERIALS)
13	MZC-0056	SCREW
14	MZC-0057	RIGHT HAND WHEEL SHAFT
15	MZC-0058	HAND WHEEL SHAFT SPRING
16	MZC-0059	HAND WHEEL SHAFT SEAT
17	MZC-0060	GUIDE CONNECTION APPARATUS
18	MZC-0061	SCREW
19	MZC-0062	SCREW
20	MZC-0063	GUIDE BLOCK FIXED SEAT
21	MZC-0064	SCREW
22	MZC-0065	SCREW
23	MZC-0066	LEFT HAND WHEEL SHAFT

(PRESS AND HAND WHEEL SYSTEM)

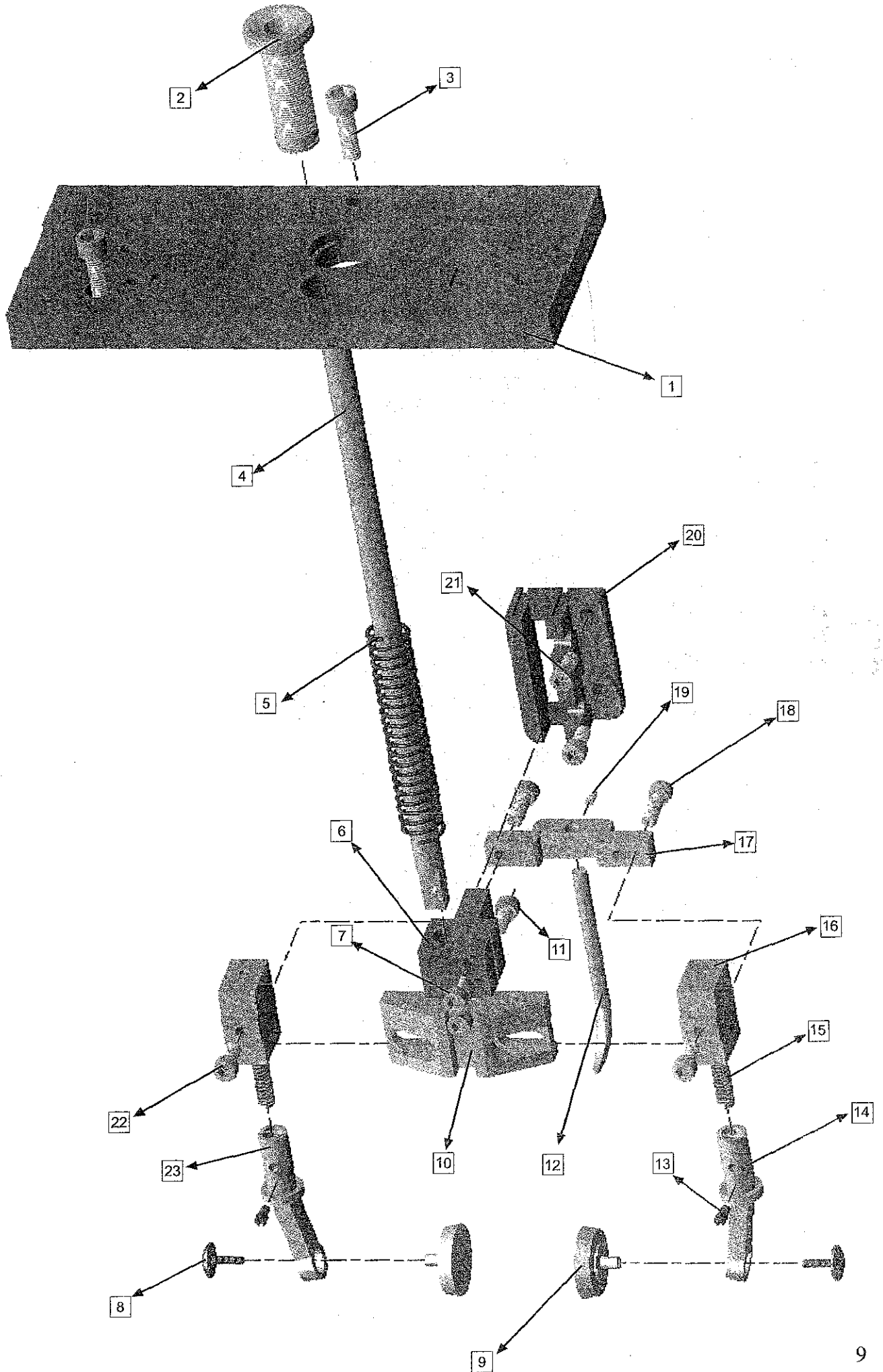

UPPER SHAFT ROTATE MECHANISM

1	MZC-0011	NEEDLE BAR CONNECTED ROD
2	MZC-0067	CAM
3	MZC-0068	THREAD TAKE UP LEVER NOZZLE
4	MZC-0069	SCREW
5	MZC-0070	THREAD TAKE UP LEVER
6	MZC-0071	THREAD RING
7	MZC-0072	THREAD TAKE UP LEVER ASSEMBLY PIN
8	MZC-0073	SCREW
9	MZC-0074	UPPER SHAFT BUSHING (FRONT)
10	MZC-0075	OIL WICK
11	MZC-0076	PROX ECCENTRIC
12	MZC-0037	ECCENTRIC
13	MZC-0028	ECCENTRIC CONNECTION SHAFT
14	MZC-0035	ECCENTRIC TONGS
15	MZC-0036	ECCENTRIC NOZZLE SCREW NUT
16	MZC-0038	ECCENTRIC WASHER
17	MZC-0077	GEAR ECCENTRIC TONGS
18	MZC-0078	ECCENTRIC SCREW
19	MZC-0079	GEAR ECCENTRIC
20	MZC-0080	HOOK ECCENTRIC WASHER
21	MZC-0081	SCREW
22	MZC-0082	HOOK ECCENTRIC
23	MZC-0083	HOOK ECCENTRIC SCREW
24	MZC-0084	HOOK ECCENTRIC TONGS
25	MZC-0085	HOOK ECCENTRIC WASHER
26	MZC-0086	SCREW
27	MZC-0087	UPPER SHAFT
28	MZC-0088	UPPER SHAFT WEDGE
29	MZC-0089	OIL WICK
30	MZC-0090	UPPER SHAFT BUSHING (BACK)
31	MZC-0091	BELT ROLLER
32	MZC-0092	LOCATING SEAT
33	MZC-0093	BELT ROLLER WASHER
34	MZC-0094	SCREW
35	MZC-0095	LOCATING SEAT SCREW

(UPPER SHAFT ROTATE MECHANISM)

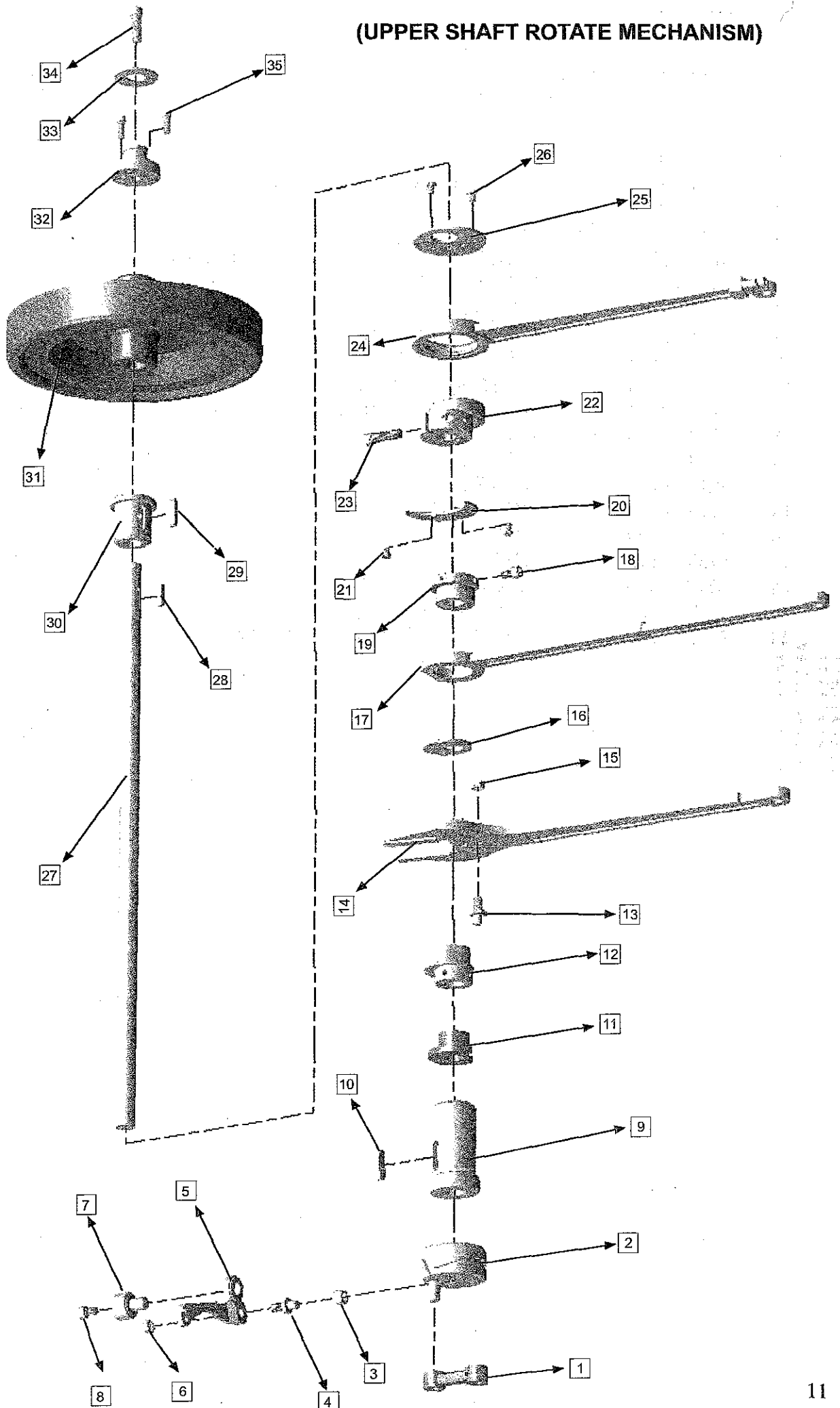

SEWING GO-COME ECCENTRIC

1	MZC-0096	E-TYPE SNAP RING
2	MZC-0097	GEAR MOTION LEVER SHAFT
3	MZC-0098	THIMBLE
4	MZC-0099	GEAR LEVER SCREW
5	MZC-0100	GEAR MOTION MECHANISM SEAT
6	MZC-0101	GEAR SHAFT
7	MZC-0102	OIL WICK
8	MZC-0103	SHAFT HOLDING
9	MZC-0104	SHAFT HOLDING SCREW
10	MZC-0105	GEAR SHAFT THIMBLE
11	MZC-0104	SHAFT HOLDING SCREW
12	MZC-0103	SHAFT HOLDING
13	MZC-0106	TONGS HOLDING
14	MZC-0107	TONGS HOLDING SCREW
15	MZC-0108	PIN HOLDING SCREW
16	MZC-0109	PIN
17	MZC-0110	THIMBLE
18	MZC-0035	ECCENTRIC TONGS
19	MZC-0037	ECCENTRIC
20	MZC-0111	GEAR MOTION MECHANISM SCREW

(SEWING GO-COME ECCENTRIC)

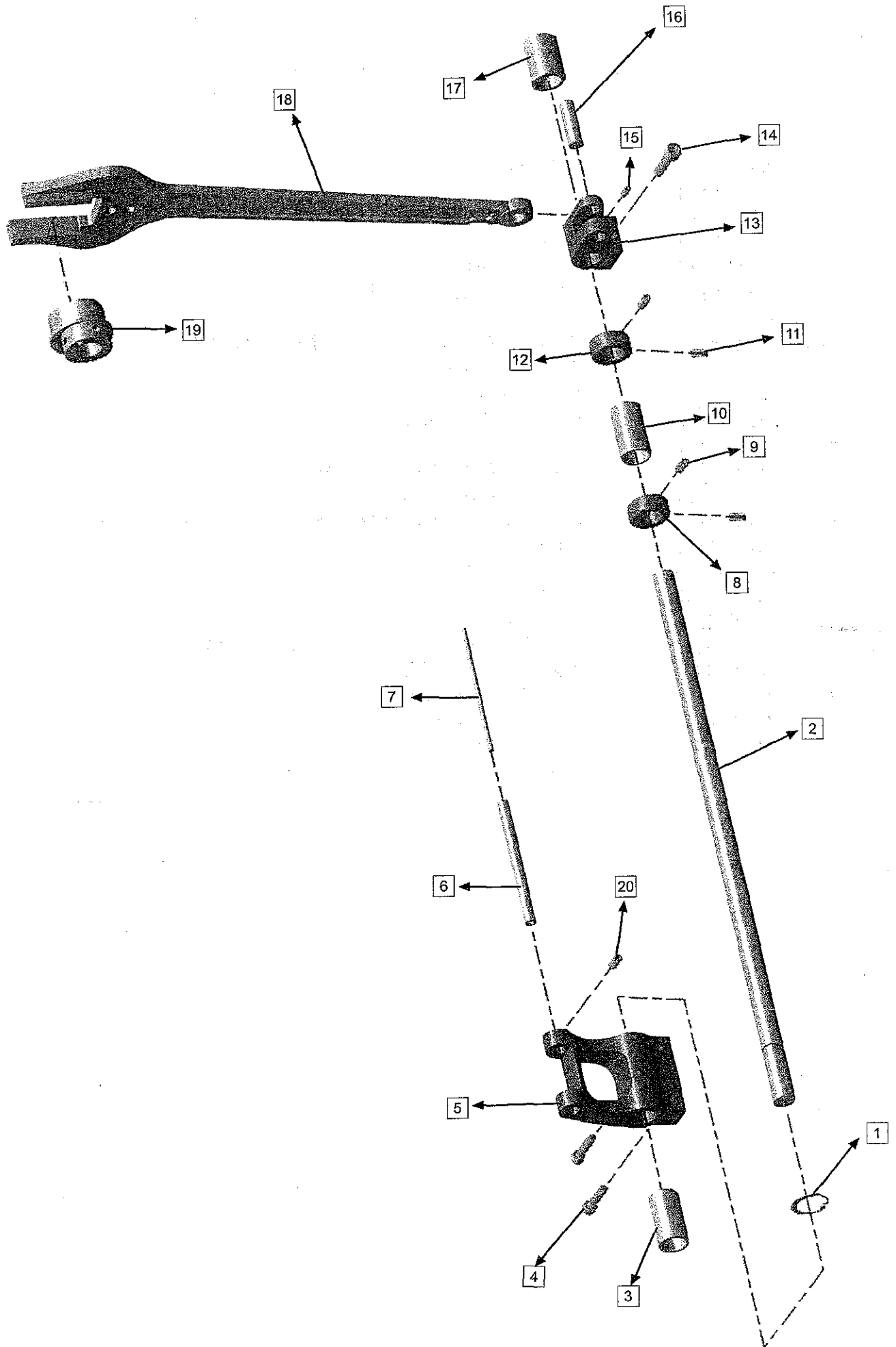

GO-COME GEAR ECCENTRIC SCHEME

1	MZC-0112	NUT
2	MZC-0113	SCREW
3	MZC-0114	JOINT
4	MZC-0113	SCREW
5	MZC-0112	NUT
6	MZC-0115	GEAR SCREW
7	MZC-0116	GEAR ASSEMBLY SET
8	MZC-0117	GEAR
9	MZC-0100	GEAR MOVEMENT MECHANISM SEAT
10	MZC-0101	GEAR SHAFT
11	MZC-0102	OIL WICK
12	MZC-0118	GO-COME GEAR SHAFT
13	MZC-0119	THIMBLE
14	MZC-0120	SHAFT HOLDING SCREW
15	MZC-0121	SHAFT HOLDING
16	MZC-0122	SCREW OF GEAR TONGS CONNECTION SEAT
17	MZC-0123	NUT
18	MZC-0124	GEAR TONGS CONNECTION SEAT
19	MZC-0125	NUT
20	MZC-0126	THIMBLE
21	MZC-0127	GEAR TONGS CONNECTION SCREW
22	MZC-0077	GEAR ECCENTRIC TONGS
23	MZC-0128	E-TYPE SNAP RING
24	MZC-0038	ECCENTRIC WASHER
25	MZC-0079	GEAR ECCENTRIC

(GO-COME GEAR ECCENTRIC SCHEME)

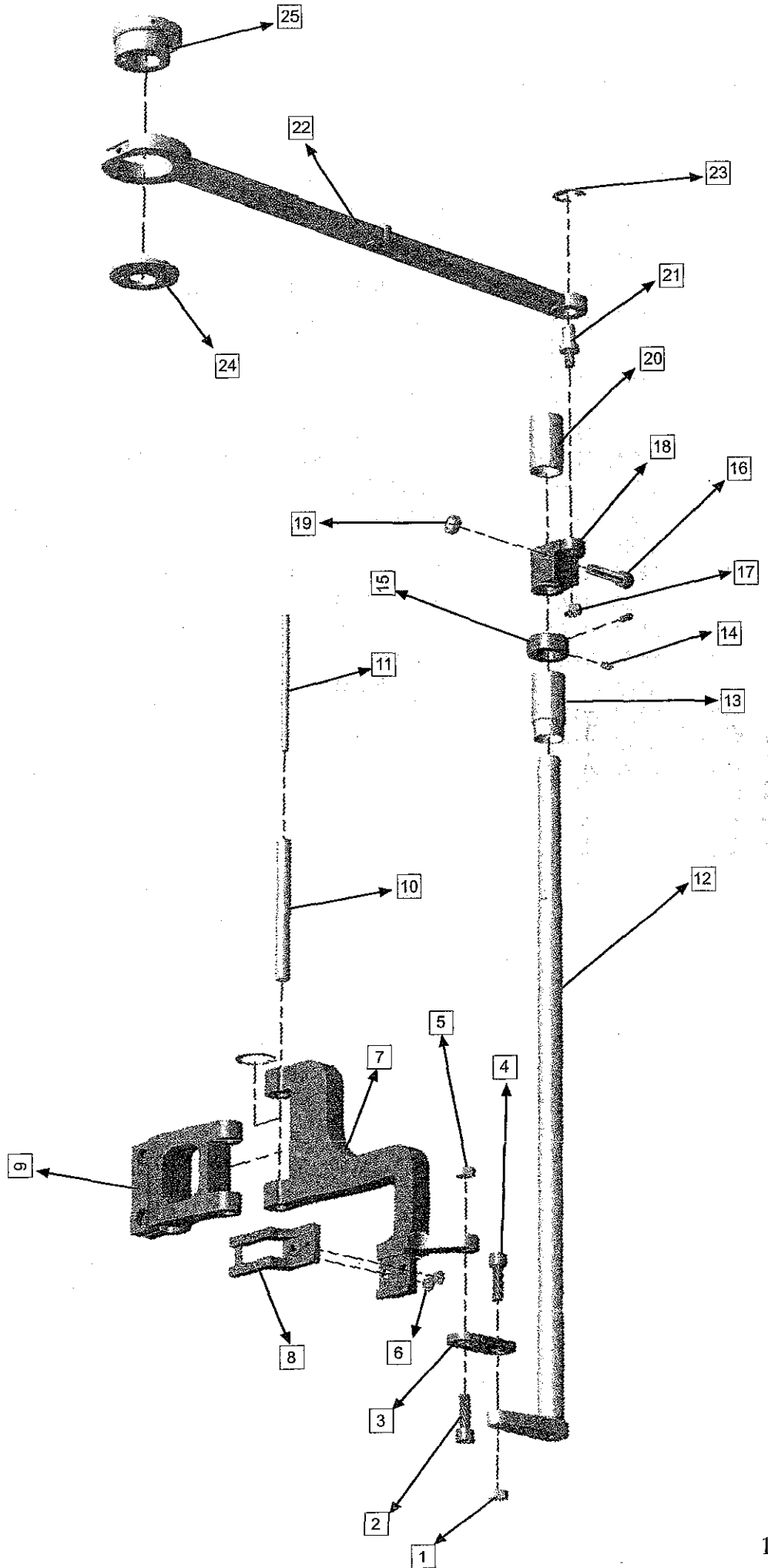

HOOK MOTION MECHANISM

1	MZC-0129	GEAR SCREW
2	MZC-0129	GEAR SCREW
3	MZC-0130	GEAR
4	MZC-0131	THIMBLE
5	MZC-0132	HOOK BEARING SHAFT
6	MZC-0133	FIXED RING
7	MZC-0134	SCREW
8	MZC-0135	CONNECTED SEAT
9	MZC-0136	SCREW
10	MZC-0137	HOOK SHAFT
11	MZC-0138	HOOK SHAFT FIXED RING
12	MZC-0139	THIMBLE
13	MZC-0140	GEAR
14	MZC-0141	PIN
15	MZC-0142	GEAR BEARING
16	MZC-0143	THIMBLE
17	MZC-0144	GEAR BEARING SHAFT
18	MZC-0145	GEAR
19	MZC-1046	WASHER
20	MZC-0147	SCREW
21	MZC-0148	PIN
22	MZC-0149	SCREW

(HOOK MOTION MECHANISM)

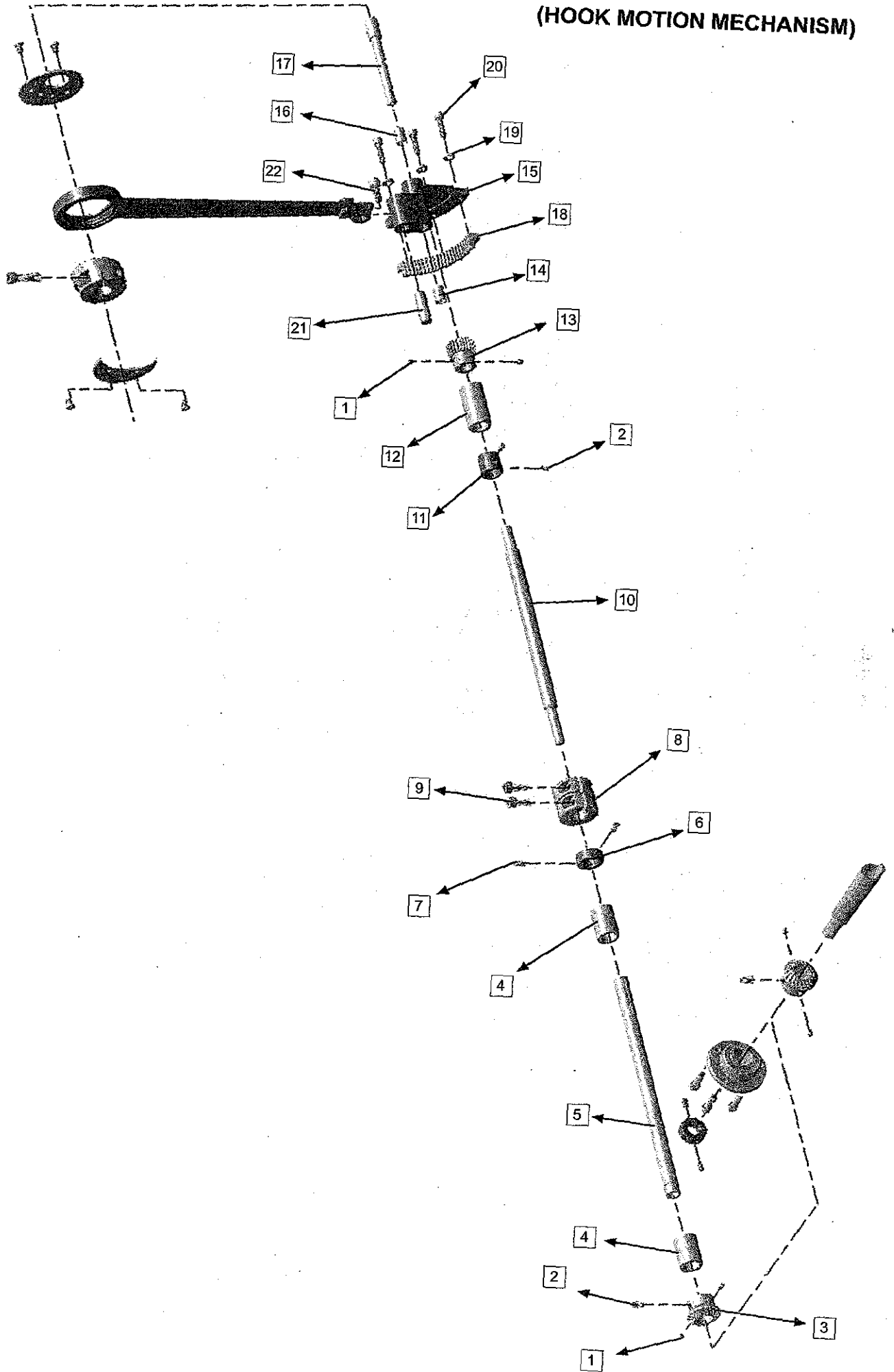

HOOK MECHANISM

1	MZC-0150	SET NUT
2	MZC-0151	SCREW
3	MZC-0152	SCREW
4	MZC-0153	FIXED SEAT
5	MZC-0154	SCREW
6	MZC-0155	GEAR
7	MZC-0156	SPINDLE
8	MZC-0157	SCREW
9	MZC-1058	NEEDLE BRACKET
10	MZC-0159	FLAT PIN
11	MZC-0160	SCREW
12	MZC-0161	COVER
13	MZC-0162	HOOK BEARING CASTING
14	MZC-0163	PIN
15	MZC-0164	SCREW
16	MZC-0165	PIN
17	MZC-0166	SCREW
18	MZC-0167	SCREW
19	MZC-0168	THIMBLE
20	MZC-0169	HOOK LOWER BEARING THIMBLE
21	MZC-0170	HOOK BEARING
22	MZC-0171	HOOK BEARING UPPER COVER
23	MZC-0172	HOOK DRIVER
24	MZC-0173	HOOK DRIVER ASSEMBLY SCREW
25	MZC-0174	NUT
26	MZC-0175	BEARING LATCH
27	MZC-0176	SCREW
28	MZC-0177	PIN
29	MZC-0178	BEARING LATCH SEAT
30	MZC-0179	PRESS SPRING
31	MZC-0180	PRESS SPRING SCREW
32	MZC-0181	SCREW
33	MZC-0182	COVER
34	MZC-0183	HOOK
35	MZC-0184	BOBBIN

(HOOK MECHANISM)

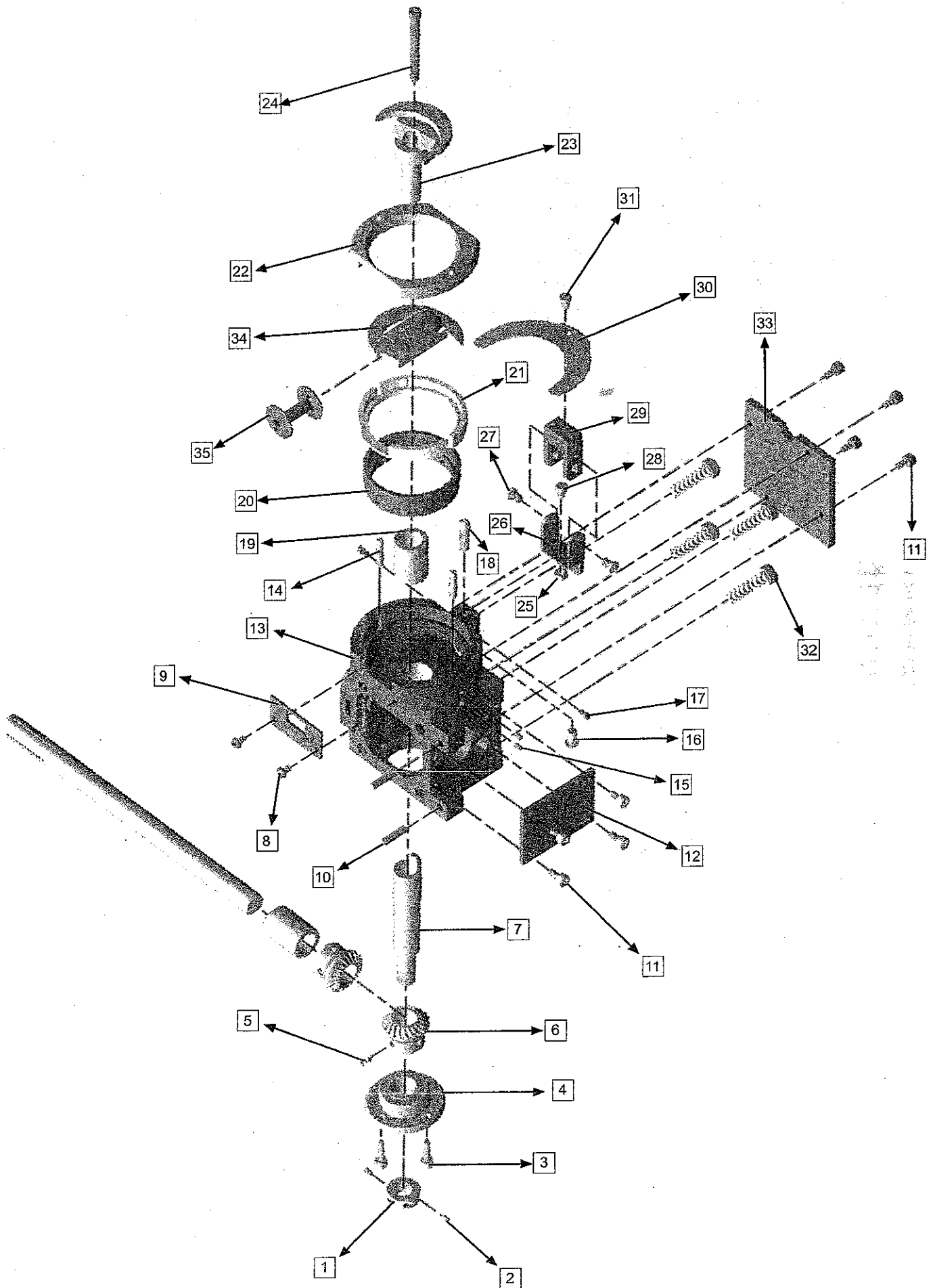

STOP-GO MECHANISM

1	MZC-0079	GEAR ECCENTRIC
2	MZC-0077	GEAR ECCENTRIC TONGS
3	MZC-0185	SCREW
4	MZC-0038	ECCENTRIC WASHER
5	MZC-0186	TONGS CONNECTION PIN
6	MZC-0187	ROTARY DRIVE SEAT
7	MZC-0188	ROTARY DRIVE
8	MZC-0189	SCREW
9	MZC-0190	SCREW
10	MZC-0191	CONNECTION SEAT OF ROTARY DRIVE SEAT
11	MZC-0192	SCREW

(STOP-GO MECHANISM)

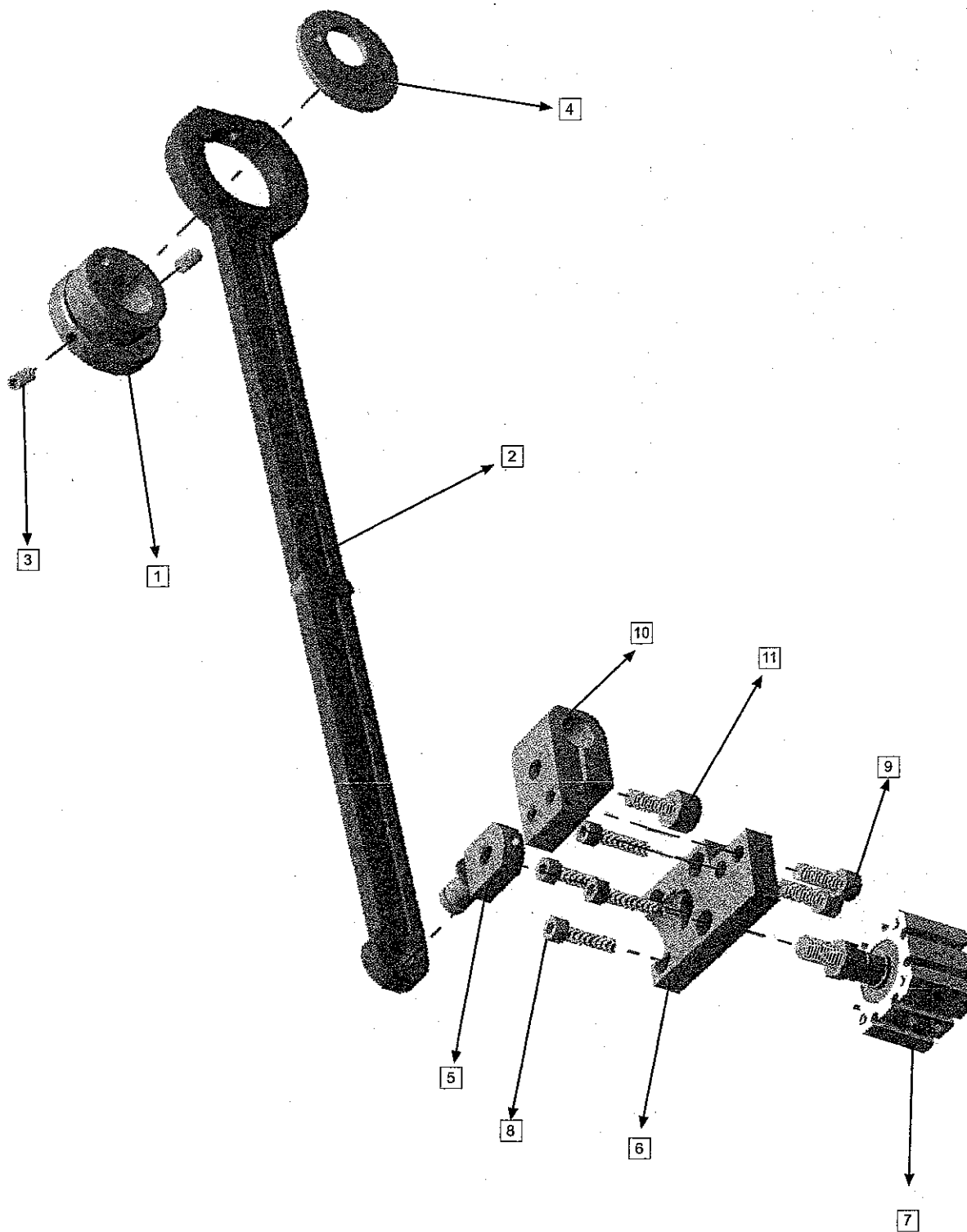

STOP-GO MECHANISM (NEW MODEL)

1	MZC-0079	GEAR ECCENTRIC
2	MZC-0077	GEAR ECCENTRIC TONGS
3	MZC-0185	SCREW
4	MZC-0038	ECCENTRIC WASHER
5	MZC-0193	TONGS CONNECTION SEAT
6	MZC-0194	TONGS CONNECTION PIN
7	MZC-0195	THIMBLE
8	MZC-0196	JOINT
9	MZC-0197	SCREW
10	MZC-0189	SCREW
11	MZC-0187	ROTARY DRIVE SEAT
12	MZC-0198	ROTARY DRIVE
13	MZC-0199	SCREW
14	MZC-0192	SCREW
15	MZC-0200	THIMBLE
16	MZC-0191	CONNECTION SEAT OF ROTARY DRIVE SEAT

(STOP-GO MECHANISM) (NEW MODEL)

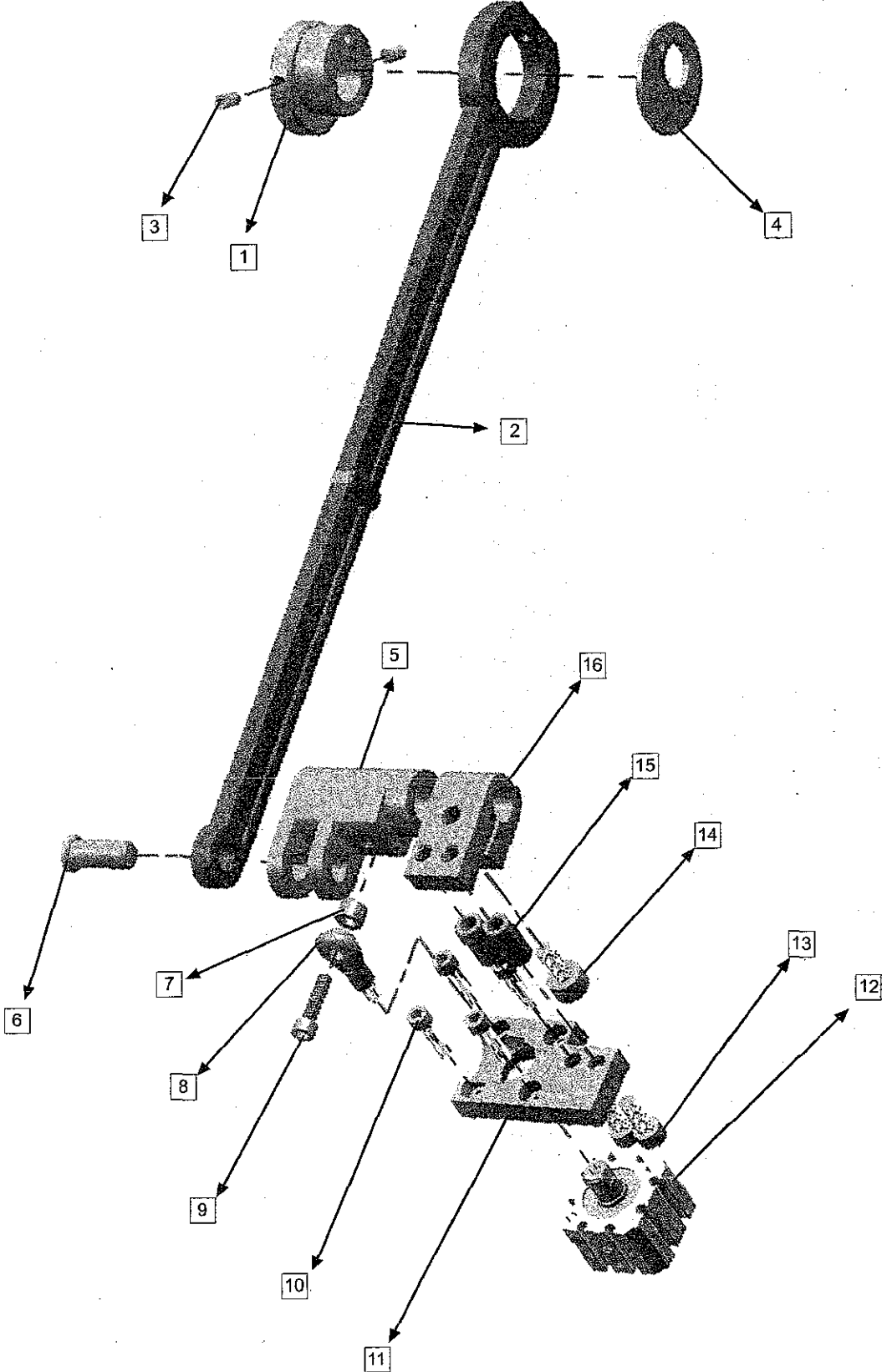

THREAD ROD MECHANISM

1	MZC-0201	NUT
2	MZC-0202	WASHER
3	MZC-0203	SPRING
4	MZC-0204	WASHER
5	MZC-0205	WASHER
6	MZC-0205	WASHER
7	MZC-0206	TENSION SHAFT
8	MZC-0207	NUT
9	MZC-0208	SCREW
10	MZC-0209	THREAD ROAD
11	MZC-0210	SCREW
12	MZC-0211	ROTARY DRIVE SEAT
13	MZC-0212	ROTARY DRIVE
14	MZC-0213	SILINCER
15	MZC-0214	ROTARY DRIVE INNER MECHANISM
16	MZC-0215	ROTARY DRIVE INNER MECHANISM
17	MZC-0216	ROTARY DRIVE SEAT
18	MZC-0217	SCREW
19	MZC-0218	TENSION PIN
20	MZC-0219	TENSION OPENING SEAT
21	MZC-0220	SCREW
22	MZC-0221	NUT
23	MZC-0202	WASHER
24	MZC-0203	SPRING
25	MZC-0204	WASHER
26	MZC-0222	WASHER
27	MZC-0223	OIL WICK
28	MZC-0224	THREAD ROAD
29	MZC-0224	THREAD ROAD
30	MZC-0223	OIL WICK
31	MZC-0222	WASHER
32	MZC-0225	TENSION SHAFT
33	MZC-0226	SPRING
34	MZC-0227	SPRING
35	MZC-0228	SPRING HOLDING
36	MZC-0229	SCREW
37	MZC-0230	SPRING HOLDING
38	MZC-0231	FRONT COVER
39	MZC-0232	SCREW
40	MZC-0233	THREAD TAKE UP LEVER PROTECTION
41	MZC-0234	NUT

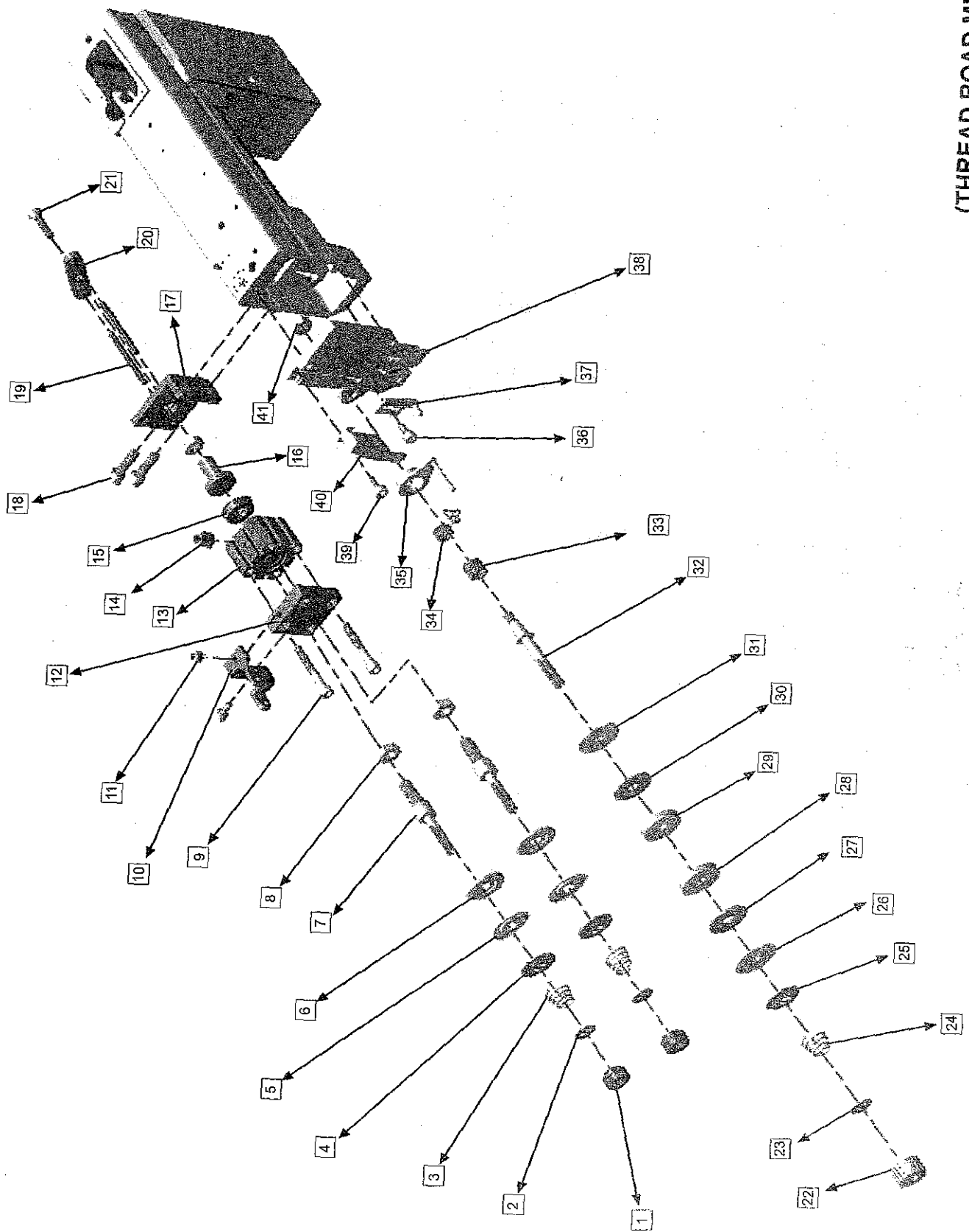

(THREAD ROAD MECHANISM)

BODY ASSEMBLY

1	MZC-0235	SIDE COVER
2	MZC-0236	SIDE COVER SCREW
3	MZC-0237	UPPER COVER
4	MZC-0238	UPPER COVER SCREW
5	MZC-0239	THREAD POST
6	MZC-0240	UPPER BODY
7	MZC-0241	THREAD TAKE UP LEVER SCREW
8	MZC-0231	FRONT COVER
9	MZC-0242	SCREW
10	MZC-0243	PLATE
11	MZC-0244	PLATE SCREW
12	MZC-0245	RIGHT SLIDE COVER
13	MZC-0246	BOTTOM BODY
14	MZC-0247	LEFT SLIDE COVER
15	MZC-0248	SLIDE COVER SPRING
16	MZC-0249	SCREW
17	MZC-0250	OIL STOPPER
18	MZC-0251	WASHER
19	MZC-0252	SCREW

(BODY ASSEMBLY)

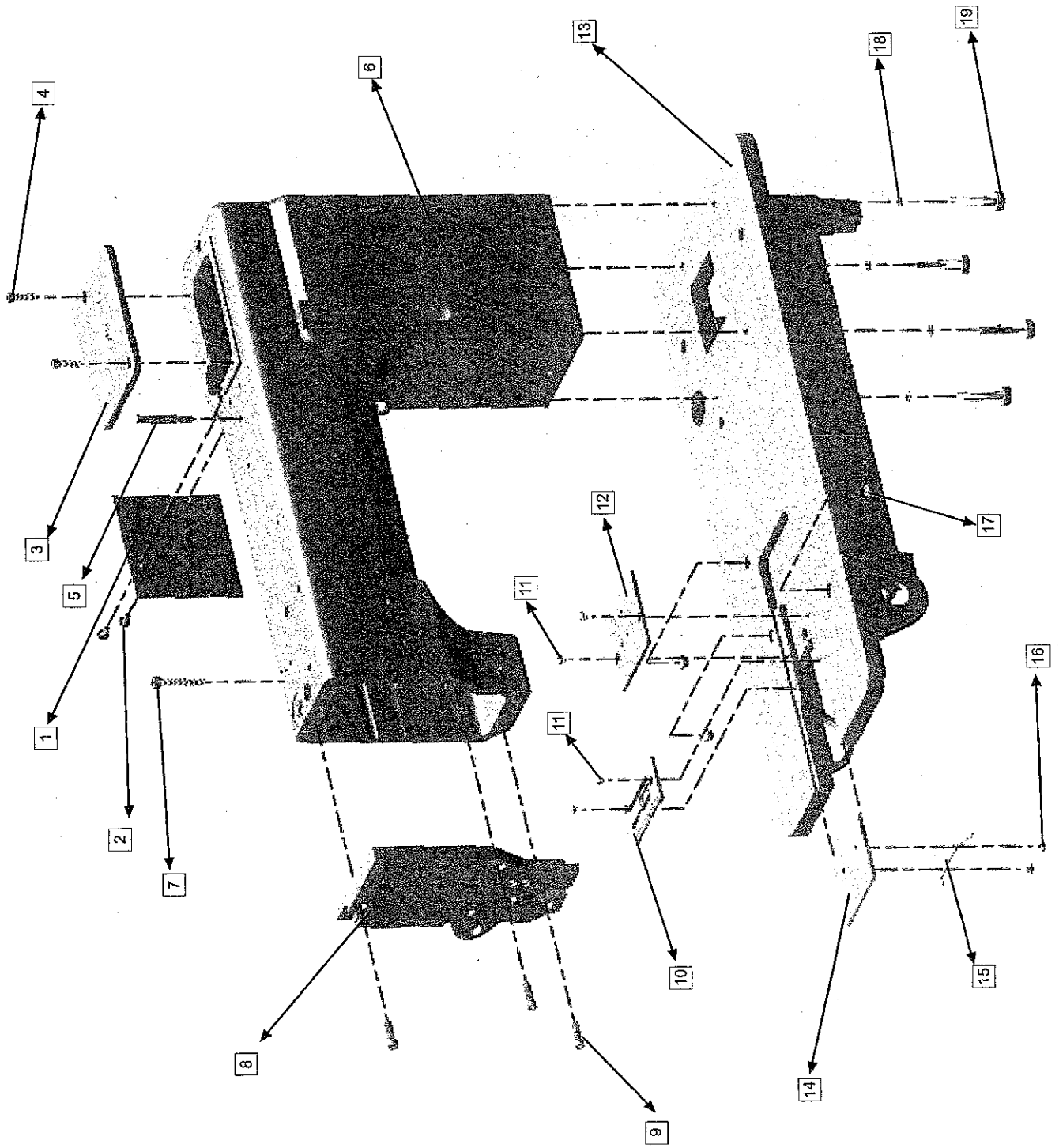

UPPER COVER ASSEMBLY

1	MZC-0253	UPPER BODY
2	MZC-0254	BACK COVER
3	MZC-0255	SCREW
4	MZC-0256	BACK COVER
5	MZC-0257	UPPER COVER
6	MZC-0258	MONITOR
7	MZC-0259	MONITOR ASSEMBLY HANDCUFFS
8	MZC-0260	MONITOR ASSEMBLY HANDCUFFS SCREW

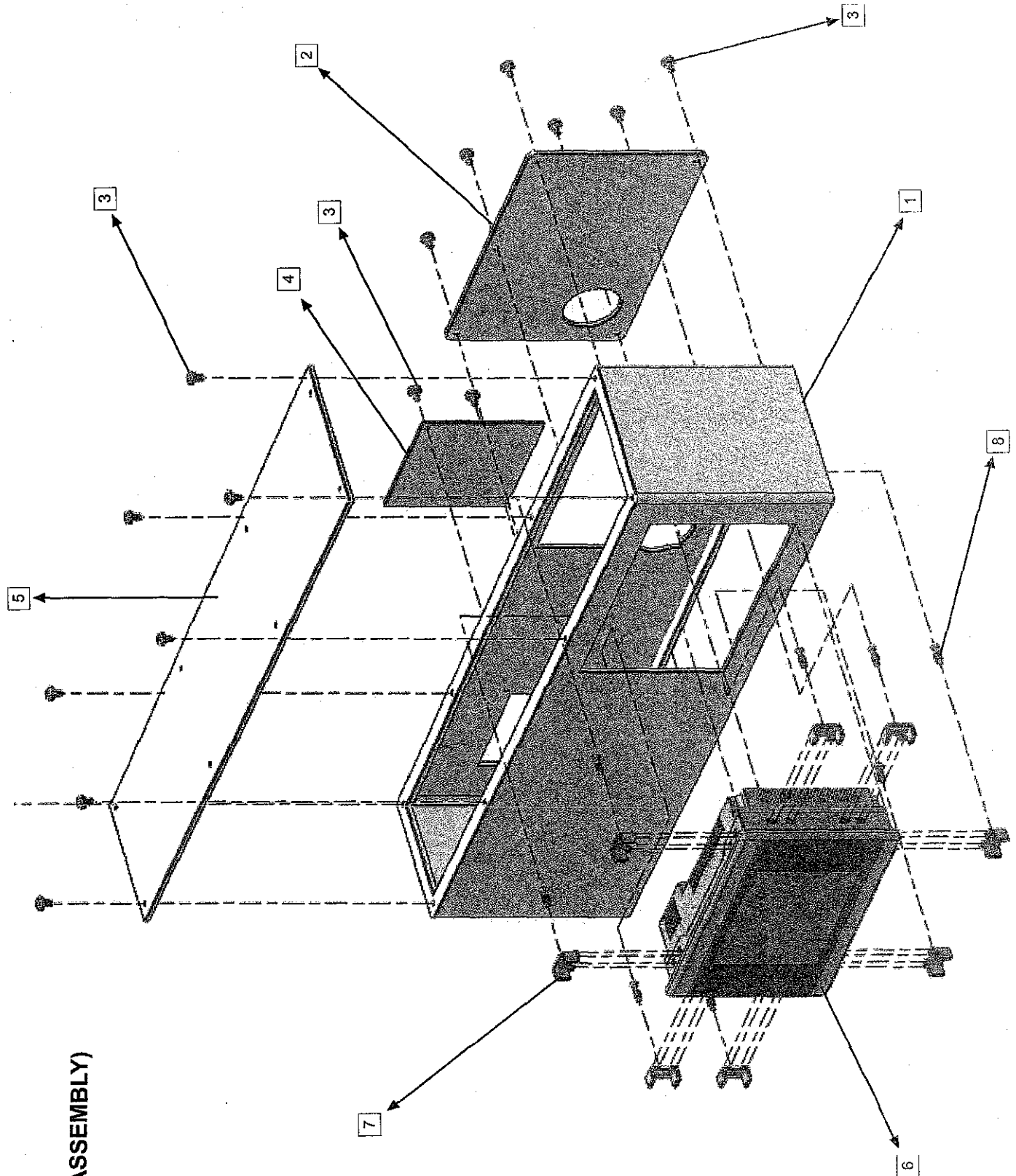

(UPPER COVER ASSEMBLY)

PNEUMATIC AND VALVE CONNECTION SCHEME

(ROTARY) → P40=P0 → G0 → C0

(STOP-GO) → P41=P1 → G1 → C1

(GO-BACK) → P42=P2 → G2 → C2

(FOOT LIFTING) → P3 → G3 → C3

G0
G1
G2
G3



(WOLF AIR ENTRIES)

C0
C1
C2
C3



(WOLF AIR EXITS)

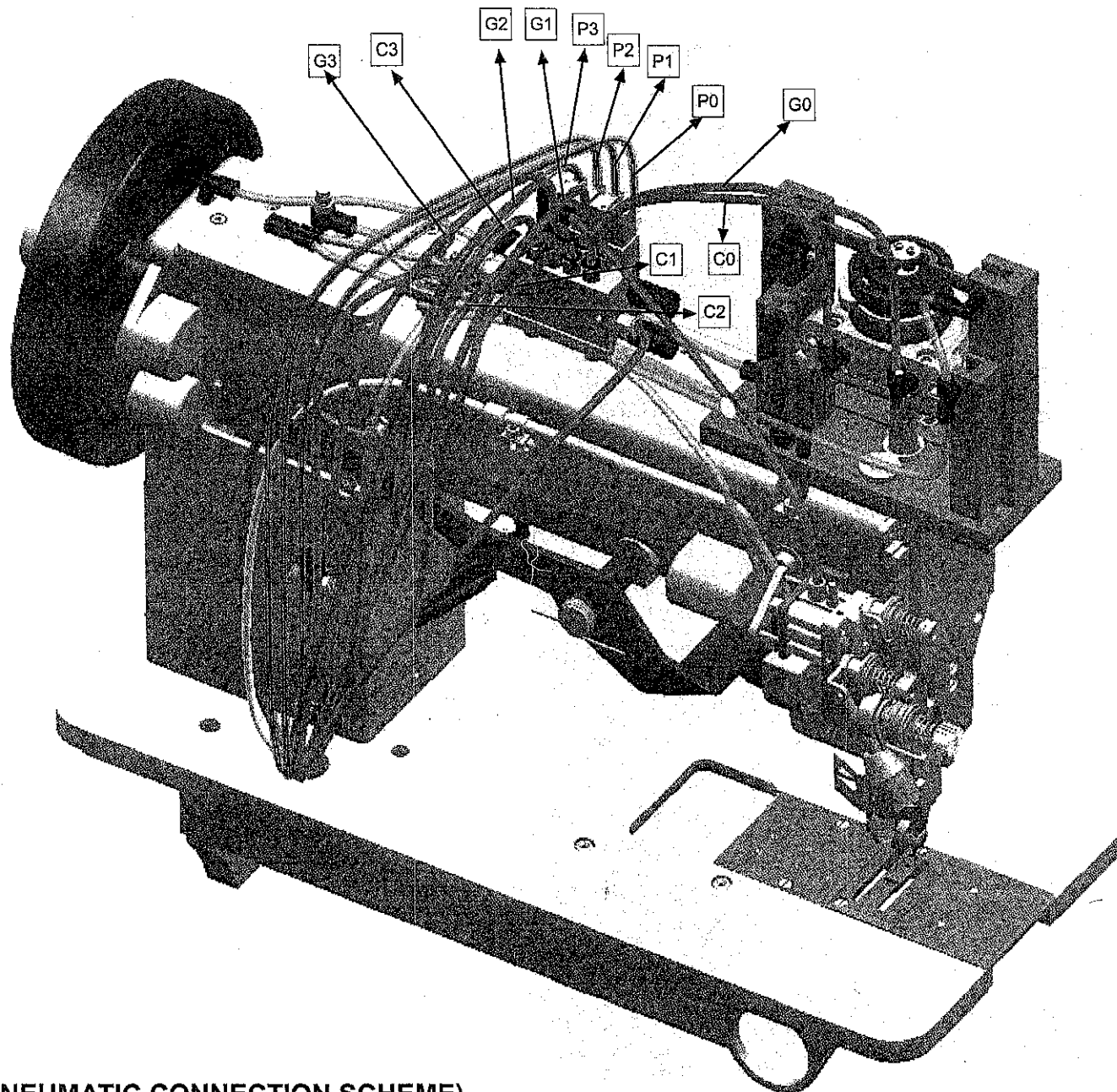

(PNEUMATIC CONNECTION SCHEME)

From the Library of Superior Sewing Machine & Supply LLC

PLC

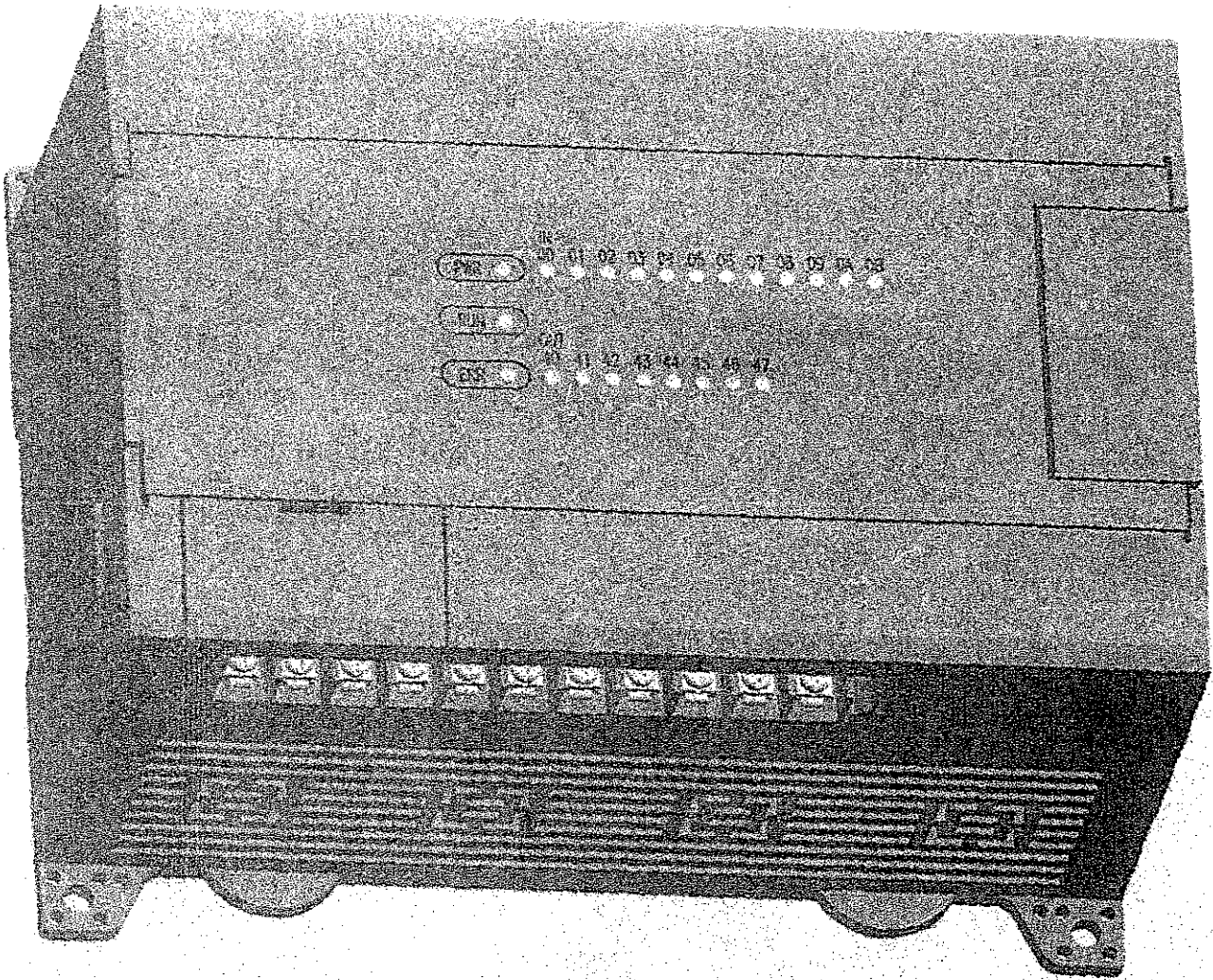

P40
P41
P42



(PLC CONNECTION)

P0
P1
P2
P3



(WOLF CONNECTION)

(ACCESSORYS)

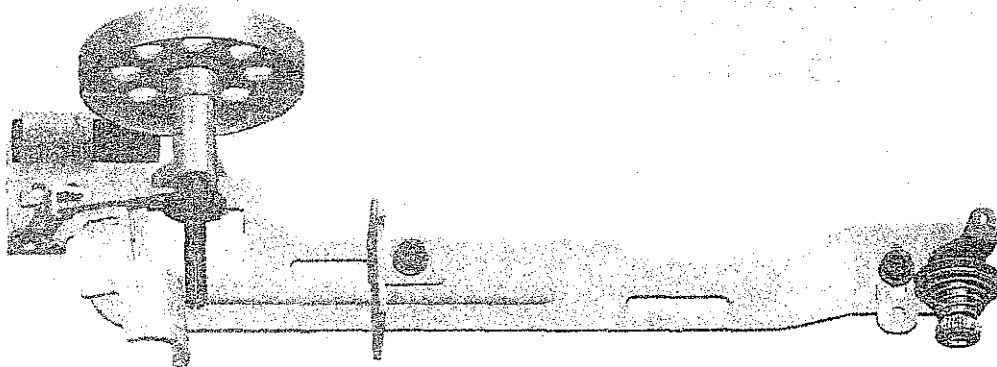

MASURA SARMA MEKANİZMASI

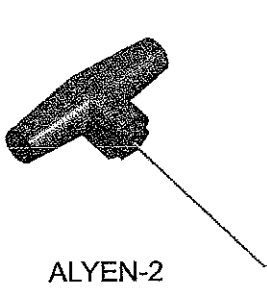

ALYEN-2

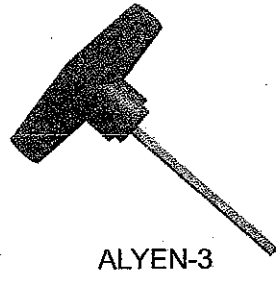

ALYEN-3



ALYEN-4



ALYEN-5

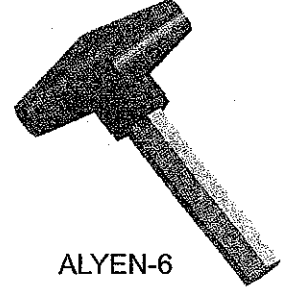

ALYEN-6

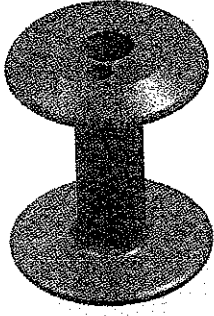

MASURA

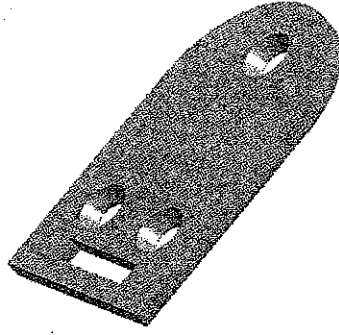

ŞAMREL DEMİRİ

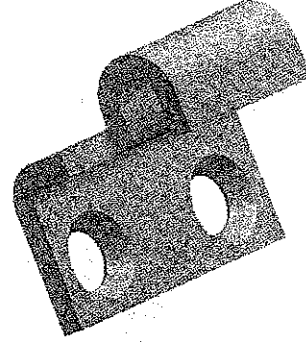

ŞAMREL DEMİRİ
KANCASI

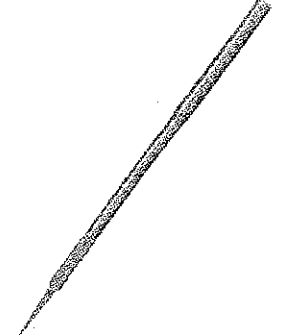

İĞNE

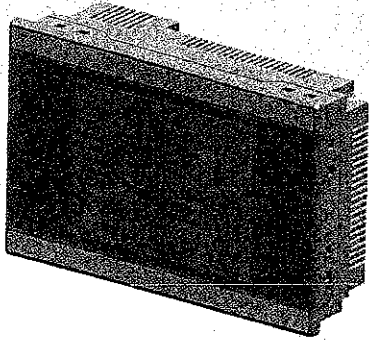

MONİTÖR

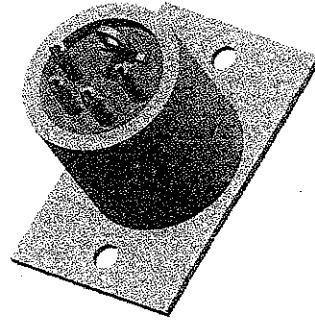

ERKEK SOKET



HAVA TABANCASI

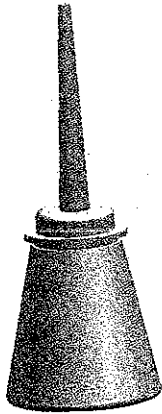

YAĞDANLIK



DAYAMA TAKOZU

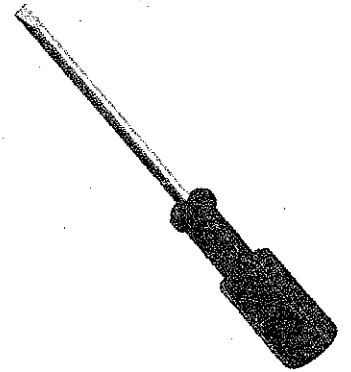

TORNAVİDA

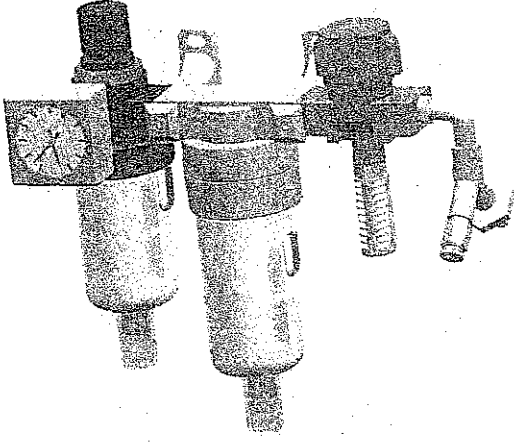

HAVA BASINÇ ÜNİTESİ VE KURUTUCUSU

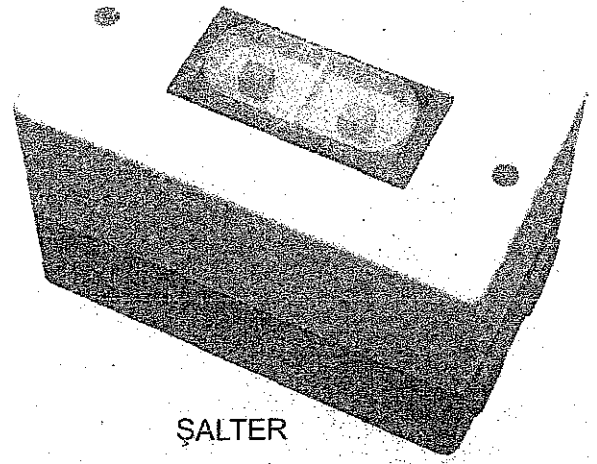

ŞALTER

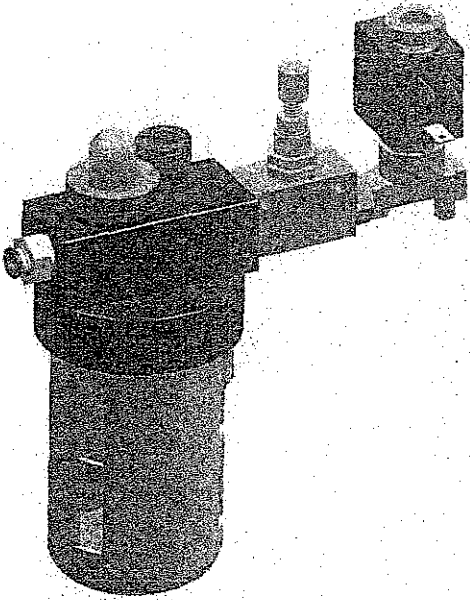

YAĞLAMA ÜNİTESİ

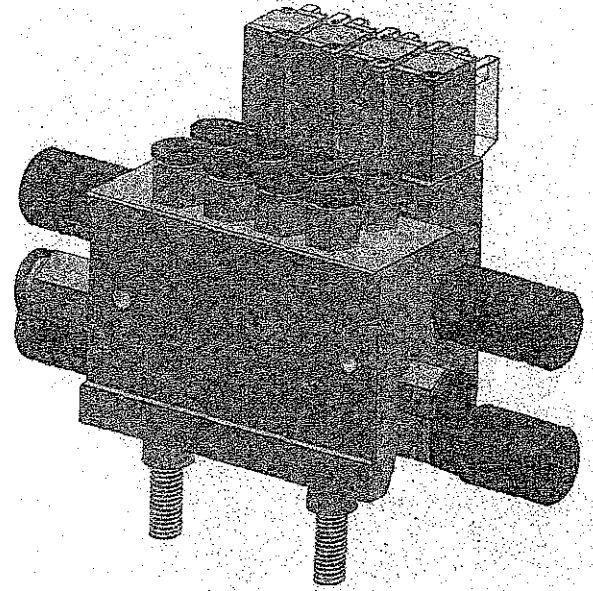

VALF GRUBU

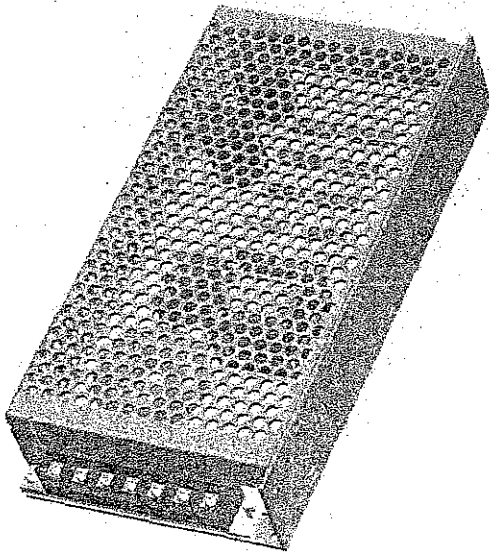

BESLEME

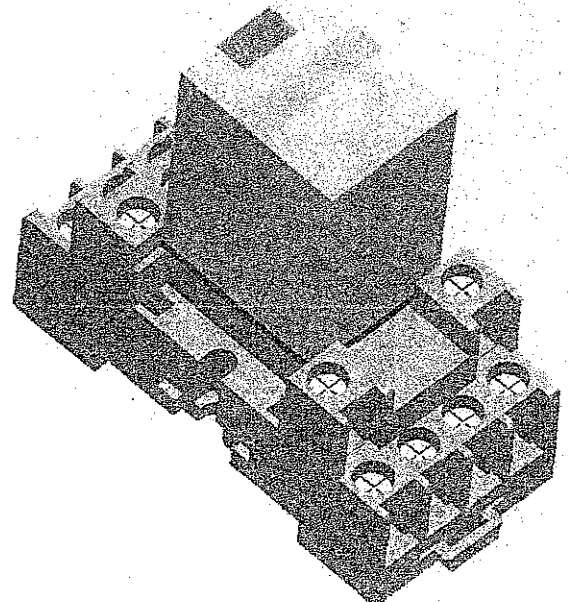

RÖLE VE RÖLE YATAĞI

THE TECHNICAL SPECIFICATIONS OF GLOBAL OS 7700 P

- 1) The stitch width of the machine is 6mm as standard, but it can be raised to 7.5mm by changing the equipment.
- 2) Automatic lubrication is available, also the lubrication period and the quantity can be programmed by user.
- 3) the measure of the thread on the bobbin can be programmed and loaded by user, warning function is available before end of the bobbin.
- 4) 140 designs are available in the memory. 100 designs are presented to the user as programmed. Also, user can create different designs and use them later by recording in to the memory.
- 5) PLC control unit is available, electronic defects have been reduced to the minimum level thanks to PLC.

PLC allows developing of the changes concerning program, which will be made later, and recording. Furthermore, digital screen is available; user can reach to the menus as practically without problem thanks to this digital screen.

- 6) When the machine is opened, user should enter own personal code for security, otherwise the security program will not allow to work.
- 7) when the bar level, the machine needs, falls down to the dangerous low bar level, the machine protects itself by cutting the electricity of the motor thanks to the control unit of bar level.
- 8) the machine turns the needle shaft as automatic like equivalent machines, but as different from the others the abrasion and blanks which can be occurred in the course of time have been minimized by minimizing the mechanic connection elements. A lot of designs can be created thanks to the feature of automatic back-sew, and we have to indicate that only this machine has got this feature.
- 9) Pneumatic foot lifter system is available; the roller foot allows to the soft descent onto the material will be sewn thanks to the feature of the reducing air.
- 10) The Needle system: DYx3
 7x23
- 11) Needle thickness: 160/23
 230/26
- 12) Thread thickness: 0.8-1.8 mm
- 13) 9 different language alternatives are available
- 14) User can reach to the trouble shooting guide for the problems by tracking the screens on the panel.

CREATING DESIGN

Pls browse to the option of the creating design by following menu on the user screen and there are small boxes from 1 to 32 on the upper side of the screen and you can switch these boxes on and off as independent from each other. "0" indicates the switched off and "1" indicates the switched on positions.

The number of the boxes indicates you step number of the design you will create. namely, show the number of needle submergence. The step number of the design should not exceed 32 in step number. Your machine creates the designs automatic by stopping the gear, turning the needless and going back.

Step 1

First, the design has to be prepared on the paper.

Step 2

The sewing direct, the begining and ending points of the design are determined like the next table. The number of the needle submergence has been determined as ten needle submergence in the sample design and this number has to be written into "STEP NUMBER" part.

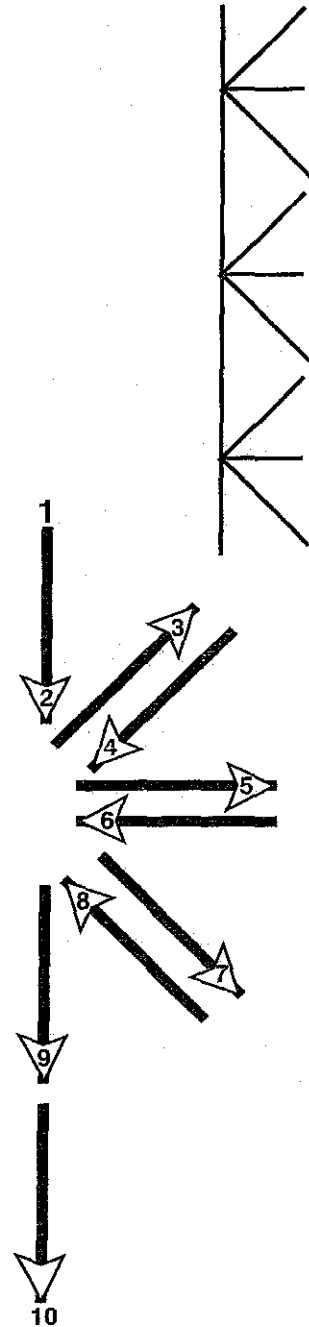

Step 3

In the table next;

A: column indicates "ROTATE"

B: column indicates "STOP&GO"

C: column indicates "GO BACK"

First, you have start with rotate.

You can write the values of the

rotate downwards until 32

into A column.

If the values of the A column are 0
the needle is at the left side.

If the values of the A column are 1
the needle is at the right side.

In the sample design;

First point:

The needle is at the left side and value is 0.

second point:

The needle is at the left side and value is 0.

third point:

The needle is at the right side and value is 1.

fourth point:

The needle is at the left side and value is 0.

fifth point:

The needle is at the right side and value is 1.

sixth point:

The needle is at the left side and value is 0.

seventh point:

The needle is at the right side and value is 1.

eighth point:

The needle is at the left side and value is 0.

ninth point:

The needle is at the left side and value is 0.

tenth point:

The needle is at the left side and value is 0.

Transfer all of these numbers from above down, in turn in order to A column, namely, convert the lines numbered 3,5,7 to "1" also, in the panel, you will switch on the boxes numbered 3,5,7 and then push to the "ROTATE" key, thus, the "ROTATE" has been completed.

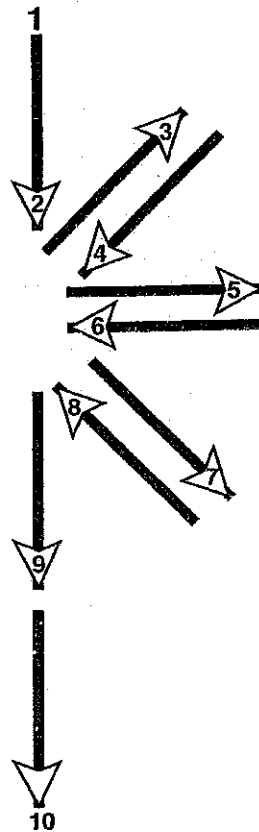

	A	B	C
1	0	0	0
2	0	0	0
3	1	0	0
4	0	0	0
5	1	0	0
6	0	0	0
7	1	0	0
8	0	0	0
9	0	0	0
10	0	0	0
11	0	0	0
12	0	0	0
13	0	0	0
14	0	0	0
15	0	0	0
16	0	0	0

Step 4

B column: "STOP&GO"

While doing the process of the "ROTATE", you had benefited from needle submergence points, but, you will base the arrow number of the sample design in the processes of the "STOP&GO" and the "GO BACK".

There are 9 arrows in the sample design, but since the step number is 10, always, you have to leave empty the first line of B and C columns.

the left and right arrow syndicate the "STOP&GO" process in each design. We can explain the sample design like this;

- 1 left front
- 2 right back
- 3 left front
- 4 right stop
- 5 left stop
- 6 right front
- 7 left back
- 8 left front
- 9 left front

In this expression, "STOP" word is in fourth and fifth lines. Instead of fourth and fifth, you have to convert fifth and sixth boxes to "1" in order to leave empty first line. Also, in the panel, we will switch on fifth and sixth boxes and push "STOP&GO" key, thus this step has been completed.

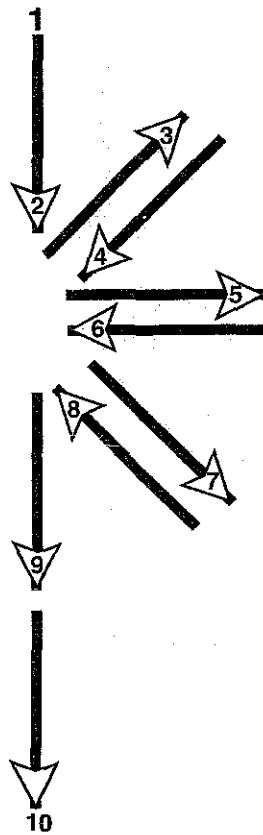

	A	B	C
1	0		
2	0	0	0
3	1	0	0
4	0	0	0
5	1	1	0
6	0	0	0
7	1	0	0
8	0	0	0
9	0	0	0
10	0	0	0
11	0	0	0
12	0	0	0
13	0	0	0
14	0	0	0
15	0	0	0
16	0	0	0

Step 5
 C column: "GO BACK"
 You can find again
 the expression below

- 1 left front
- 2 right back
- 3 left front
- 4 right stop
- 5 left stop
- 6 right front
- 7 left back
- 8 left front
- 9 left front

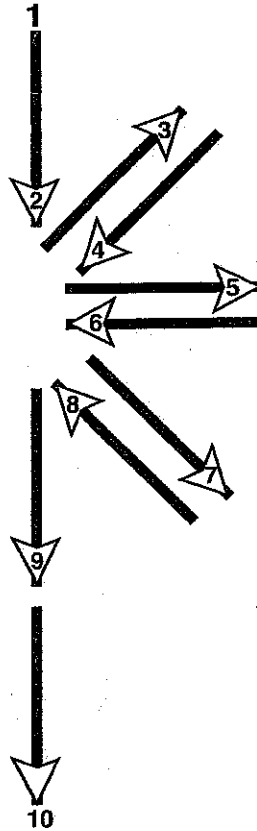

In this step, you have to find backwards arrows, you can see them in the second and seventh lines. Since a line has to be skidded in the table, you have convert third and eighth boxes of C columns to "1". also in the panel you will switch on third and eighth boxes. Then, by pushing to "GO&BACK" key enter the memory number into "RECORD NO" section and then push "RECORD" key. Then, you can sew your design you created by pushing "READ", "CALL DESIGN", keys inturn in order.

SUCCESS !!

NOTE: Each created design can be used with both single and double needle, but the design in the panel is always a single needle design. Now, it is not possible to see the appearance of double needle on the screen. If you want to see this design on the paper, draw the reverse appearance of the design onto the design you created.

	A	B	C
1	0		
2	0	0	0
3	1	0	1
4	0	0	0
5	1	1	0
6	0	1	0
7	1	0	0
8	0	0	1
9	0	0	0
10	0	0	0
11	0	0	0
12	0	0	0
13	0	0	0
14	0	0	0
15	0	0	0
16	0	0	0

SKIPPING

- 1- Be sure that the needles are not deformed.
- 2- Check whether the hook adjustment is at the correct position
 - While the needles are at the most bottom point they should be cross with the spoon middle line of the left needle hole. Before checking the line you should not start hook adjustment.
 - By turning the pulley at the turning direct of the machine bring the needles to the most bottom point. Bring the tip of the hook to the right needle line. The tip of the hook should pass from 1 mm upper of right needle hole.
 - The tip of the hook should pass from back of both needle with equal intervals. If the intervals are not equal, adjust the degree of the pneumatic piston.
 - Close the air. While the needles are at the upper position' bring the piston to the most right position and turn the pulley. The needles should submerge into the plate hole as parallel. If it is not paralel, adjust piston degree with the degree adjustment screw which is on the piston, please do same process for left side.
- 3- Have the thread and needle selection been made correct?
 - The thread thickness should be balanced according to the thickness of the thread which will be used.
- 4- Are the roller foot making complete press on the materials?
 - The roller foot press adjustment can be insufficient.
 - The roller foot press shaft can be bended and can not make full press.
 - The distance between roller foot and needle should be equal and near as far as possible.
- 5- Is the rotate of the needle shaft symmetrical at both sides?
 - Close the air. While the needles are at the upper position, bring the piston to the most right position and turn the pulley. The needles should submerge into the plate hole as parallel. If it is not paralel, adjust piston degree with the degree adjustment screw which is on the piston, please do same process for left side.
- 6- Is the height adjustment of needle shaft correct?
 - While the needles are at the most bottom point they should be cross with the spoon middle line of the left needle hole. Before checking the line you should not start hook adjustment.
 - By turning the pulley at the turning direct of the machine bring the needles to the most bottom point. Bring the tip of the hook to the right needle line. The tip of the hook should pass from 1 mm upper of right needle hole.

- The tip of the hook should pass from back of both needle with equal intervals. If the intervals are not equal, adjust the degree of the pneumatic piston.
- Close the air. While the needles are at the upper position' bring the piston to the most right position and turn the pulley. The needles should submerge into the plate hole as parallel. If it is not paralel, adjust piston degree with the degree adjustment screw which is on the piston, please do same process for left side.

7- Furthermore; please contact with technical service

NEEDLE BREAKING

1- The needles can be deformed or poor quality

2- The needles can rub to the roller foots

3- The needles can not submerge into the plate balanced

- Close the air. While the needles are at the upper position' bring the piston to the most right position and turn the pulley. The needles should submerge into the plate hole as parallel. If it is not paralel, adjust piston degree with the degree adjustment screw which is on the piston, please do same process for left side.

4- The hook adjustment can not be at correct position

- While the needles are at the most bottom point they should be cross with the spoon middle line of the left needle hole. Before checking the line you should not start hook adjustment.

- By turning the pulley at the turning direct of the machine bring the needles to the most bottom point. Bring the tip of the hook to the right needle line. The tip of the hook should pass from 1 mm upper of right needle hole.

- The tip of the hook should pass from back of both needle with equal intervals. If the intervals are not equal, adjust the degree of the pneumatic piston.

- Close the air. While the needles are at the upper position' bring the piston to the most right position and turn the pulley. The needles should submerge into the plate hole as parallel. If it is not paralel, adjust piston degree with the degree adjustment screw which is on the piston, please do same process for left side.

5- The needles can be thin according to materials.

6- The press adjustment can be lower according to materials.

THREAD DAMAGE

- 1- The needles can be thin according to the thread.
- 2- The tip of the hook can have burr
 - Clean the tip of the hook with a thin emery
- 3- The tip of the hook can become blunt
 - If the tip of the hook is become blunt, it should be changed
- 4- The plate can have burr
 - Clean the plate channel with a thin emery
- 5- The thread can be poor quality
- 6- Check the thread ways

THREAD BREAKING

- 1- The needle can be thinner according to the thread.
- 2- The thread can be poor quality
- 3- Check the thread ways
- 4- The hook bearing can be entwined with the thread

TENSION PROBLEMS

- 1- The needle can be thinner according to the thread.
- 2- The thread can be poor quality
- 3- Check the thread ways
- 4- Check the tension adjustment

DESIGN PROBLEMS

- 1- If the design, which is being sewn, is different than the design at the screen
 - Go to the main menu, then push sequential the buttons; READ, CALL DESIGN, MACHINE IS READY
 - If there is any piston which is not working, check the electric connections.
- 2- Loading a new design

AIR PROBLEMS

- 1- The pressure controller should not be less than 6 bar pressure
- 2- The minimum pressure level of your air compressor should be 6.5 bar.



<table border="1"><tr><td>+</td><td>+</td><td>+</td></tr><tr><td>—</td><td>—</td><td>—</td></tr></table>	+	+	+	—	—	—	<table border="1"><tr><td>READ</td><td>CALL DESIGN</td></tr><tr><td colspan="2">MACHINE IS READY</td></tr><tr><td>MENU</td><td><table border="1"><tr><td></td><td>SQUARE STITCH</td></tr></table></td></tr></table>	READ	CALL DESIGN	MACHINE IS READY		MENU	<table border="1"><tr><td></td><td>SQUARE STITCH</td></tr></table>		SQUARE STITCH
+	+	+													
—	—	—													
READ	CALL DESIGN														
MACHINE IS READY															
MENU	<table border="1"><tr><td></td><td>SQUARE STITCH</td></tr></table>		SQUARE STITCH												
	SQUARE STITCH														
PROXY	NEEDLE	STOP&GO	GO BACK												
<input type="text"/>	<input type="text"/>	<input type="text"/>	<input type="text"/>												

MENU

LUBRICATION ADJUSTMENT
BOBBIN COUNTER
LANGUAGE SELECTION
GENERATE DESIGN
TROUBLESHOOTING GUIDE
TECHNICAL SUPPORT
SPECIFICATIONS

LUBRICATION ADJUSTMENT

OILING PERIOD	0.1	50.0	sec
OILING SPACE	0	1	puls

BOBBIN COUNTER

BOBBIN COUNTER

30 meter

NEW BOBBIN



1	2	3
4	5	6
7	8	9
DEL	0	ENT

LANGUAGE SELECTION

TURKISH	ENGLISH
DEUSTCH	ITALIAN
FRENCH	SPANISH
RUSSIAN	SRPSKI
	PORTUGUESE

GENERATE DESIGN

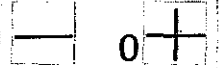
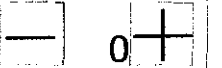
1	2	3	4	5	6	7	8	9	10	11	12	13	14	15	16
17	18	19	20	21	22	23	24	25	26	27	28	29	30	31	32
															
STEP NUMBER				RECORD NO				RECORD							
								READ							
ROTATE				0				DELETE							
STOP&GO				0				CALL DESIGN							
GO BACK				0				MENU							

TROUBLESHOOTING GUIDE

SKIPPING

NEEDLE BREAKING

THREAD DAMAGE

THREAD BREAKING

TENSION PROBLEMS

DESIGN PROBLEMS

AIR PROBLEMS

TECHNICAL SUPPORT



SKIPPING

1

BE SURE THAT THE NEEDLES ARE NOT DEFORMED.

2

CHECK WHETHER THE HOOK ADJUSTMENT IS AT THE CORRECT POSITION



3

HAVE THE THREAD AND NEEDLE SELECTION BEEN MADE CORRECT?



4

ARE THE ROLLER FOOT MAKING COMPLETE PRESS ON THE MATERIALS?



5

IS THE ROTATE OF THE NEEDLE SHAFT SYMMETRICAL AT BOTH SIDES?



6

IS THE HEIGHT ADJUSTMENT OF NEEDLE SHAFT CORRECT?



7

FURTHERMORE



CHECK WHETHER THE HOOK ADJUSTMENT IS AT THE CORRECT POSITION

2

WHILE THE NEEDLES ARE AT THE MOST BOTTOM POINT THEY SHOULD BE CROSS WITH THE SPOON MIDDLE LINE OF THE LEFT NEEDLE HOLE. BEFORE CHECKING THE LINE YOU SHOULD NOT START HOOK ADJUSTMENT.



BY TURNING THE PULLEY AT THE TURNING DIRECT OF THE MACHINE BRING THE NEEDLES TO THE MOST BOTTOM POINT. BRING THE TIP OF THE HOOK TO THE RIGHT NEEDLE LINE. THE TIP OF THE HOOK SHOULD PASS FROM 1 MM. UPPER OF RIGHT NEEDLE HOLE.

THE TIP OF THE HOOK SHOULD PASS FROM BACK OF BOTH NEEDLE WITH EQUAL INTERVALS. IF THE INTERVALS ARE NOT EQUAL, ADJUST THE DEGREE OF THE PNEUMATIC PISTON.

CLOSE THE AIR. WHILE THE NEEDLES ARE AT THE UPPER POSITION, BRING THE PISTON TO THE MOST RIGHT POSITION AND TURN THE PULLEY. THE NEEDLES SHOULD SUBMERGE INTO THE PLATE HOLE AS PARALLEL. IF IT IS NOT PARALLEL, ADJUST PISTON DEGREE WITH THE DEGREE ADJUSTMENT SCREW WHICH IS ON THE PISTON, PLEASE DO SAME PROCESS FOR LEFT SIDE.

HAVE THE THREAD AND NEEDLE SELECTION BEEN MADE CORRECT?

3

THE THREAD THICKNESS SHOULD BE BALANCED ACCORDING TO THE THICKNESS OF THE THREAD WHICH WILL BE USED

ARE THE ROLLER FOOT MAKING COMPLETE PRESS ON THE MATERIALS?

4

THE ROLLER FOOT PRESS ADJUSTMENT CAN BE INSUFFICIENT

THE ROLLER FOOT PRESS SHAFT CAN BE BENDED AND CAN NO MAKE FULL PRESS

THE DISTANCE BETWEEN ROLLER FOOT AND NEEDLE SHOULD BE EQUAL AND NEAR AS FAR AS POSSIBLE



IS THE ROTATE OF THE NEEDLE SHAFT SYMMETRICAL AT BOTH SIDES?

5

CLOSE THE AIR WHILE THE NEEDLES ARE AT THE UPPER POSITION, BRING THE PISTON TO THE MOST RIGHT POSITION AND TURN THE PULLEY. THE NEEDLES SHOULD SUBMERGE INTO THE PLATE HOLE AS PARALLEL. IF IT IS NOT PARALLEL, ADJUST PISTON DEGREE WITH THE DEGREE ADJUSTMENT SCREW WHICH IS ON THE PISTON, PLEASE DO SAME PROCESS FOR LEFT SIDE.



IS THE HEIGHT ADJUSTMENT OF NEEDLE SHAFT CORRECT?

6

WHILE THE NEEDLES ARE AT THE MOST BOTTOM POINT THEY SHOULD BE CROSS WITH THE SPOON MIDDLE LINE OF THE LEFT NEEDLE HOLE. BEFORE CHECKING THE LINE YOU SHOULD NOT START HOOK ADJUSTMENT.



BY TURNING THE PULLEY AT THE TURNING DIRECT OF THE MACHINE BRING THE NEEDLES TO THE MOST BOTTOM POINT. BRING THE TIP OF THE HOOK TO THE RIGHT NEEDLE LINE. THE TIP OF THE HOOK SHOULD PASS FROM 1 MM. UPPER OF RIGHT NEEDLE HOLE.

THE TIP OF THE HOOK SHOULD PASS FROM BACK OF BOTH NEEDLE WITH EQUAL INTERVALS. IF THE INTERVALS ARE NOT EQUAL, ADJUST THE DEGREE OF THE PNEUMATIC PISTON.

CLOSE THE AIR. WHILE THE NEEDLES ARE AT THE UPPER POSITION, BRING THE PISTON TO THE MOST RIGHT POSITION AND TURN THE PULLEY. THE NEEDLES SHOULD SUBMERGE INTO THE PLATE HOLE AS PARALLEL. IF IT IS NOT PARALLEL, ADJUST PISTON DEGREE WITH THE DEGREE ADJUSTMENT SCREW WHICH IS ON THE PISTON, PLEASE DO SAME PROCESS FOR LEFT SIDE.

FURTHERMORE

7

PLEASE

CONTACT WITH TECHNICAL

SERVICE

CONTACT

MENU

NEEDLE BREAKING

THE NEEDLES CAN BE DEFORMED OR POOR QUALITY

THE NEEDLES CAN RUB TO THE ROLLER FEET

A

THE NEEDLES CAN NOT SUBMERGE INTO THE PLATE BALANCED

B

THE HOOK ADJUSTMENT CAN NOT BE AT CORRECT POSITION

THE NEEDLES CAN BE THIN ACCORDING TO MATERIALS

THE PRESS ADJUSTMENT CAN BE LOWER ACCORDING TO MATERIALS



A

CLOSE THE AIR.WHILE THE NEEDLES ARE AT THE UPPER POSITION, BRING THE PISTON TO THE MOST RIGHT POSITION AND TURN THE PULLEY.THE NEEDLES SHOULD SUBMERGE INTO THE PLATE HOLE AS PARALLEL.IF IT IS NOT PARALLEL, ADJUST PISTON DEGREE WITH THE DEGREE ADJUSTMENT SCREW WHICH IS ON THE PISTON, PLEASE DO SAME PROCESS FOR LEFT SIDE.



B

WHILE THE NEEDLES ARE AT THE MOST BOTTOM POINT THEY SHOULD BE CROSS WITH THE SPOON MIDDLE LINE OF THE LEFT NEEDLE HOLE.BEFORE CHECKING THE LINE YOU SHOULD NOT START HOOK ADJUSTMENT.



BY TURNING THE PULLEY AT THE TURNING DIRECT OF THE MACHINE BRING THE NEEDLES TO THE MOST BOTTOM POINT. BRING THE TIP OF THE HOOK TO THE RIGHT NEEDLE LINE. THE TIP OF THE HOOK SHOULD PASS FROM 1 MM. UPPER OF RIGHT NEEDLE HOLE.

THE TIP OF THE HOOK SHOULD PASS FROM BACK OF BOTH NEEDLE WITH EQUAL INTERVALS. IF THE INTERVALS ARE NOT EQUAL, ADJUST THE DEGREE OF THE PNEUMATIC PISTON.

CLOSE THE AIR. WHILE THE NEEDLES ARE AT THE UPPER POSITION, BRING THE PISTON TO THE MOST RIGHT POSITION AND TURN THE PULLEY. THE NEEDLES SHOULD SUBMERGE INTO THE PLATE HOLE AS PARALLEL. IF IT IS NOT PARALLEL, ADJUST PISTON DEGREE WITH THE DEGREE ADJUSTMENT SCREW WHICH IS ON THE PISTON, PLEASE DO SAME PROCESS FOR LEFT SIDE.

THREAD DAMAGE

THE NEEDLES CAN BE THIN ACCORDING TO THE THREAD

1

THE TIP OF THE HOOK CAN HAVE BURR

2

THE TIP OF THE HOOK CAN BECOME BLUNT

3

THE PLATE CAN HAVE BURR

THE THREAD CAN BE POOR QUALITY

CHECK THE THREAD WAYS

1

CLEAN THE TIP OF THE HOOK WITH A THIN EMERY



2

IF THE TIP OF THE HOOK IS BECOME BLUNT, IT SHOULD BE CHANGED



3

CLEAN THE PLATE CHANNEL WITH A THIN EMERY



THREAD BREAKING

THE NEEDLES CAN BE THINNER ACCORDING TO THE THREAD

THE THREAD CAN BE POOR QUALITY

CHECK THE THREAD WAYS

THE HOOK BEARING CAN BE ENTWINED WITH THE THREAD

TENSION PROBLEMS

THE NEEDLE CAN BE THINNER ACCORDING TO THE THREAD

THE THREAD CAN BE POOR QUALITY

CHECK THE THREAD WAYS

CHECK THE TENSION ADJUSTMENT

DESIGN PROBLEMS

1

IF THE DESIGN, WHICH IS BEING SEWN, IS DIFFERENT THAN THE DESIGN AT THE SCREEN.

2

LOADING A NEW DESIGN

1

GO TO THE MAIN MENU, THEN PUSH SEQUENTIAL THE BUTTONS; READ, CALL DESIGN,
MACHINE IS READY

IF THERE IS ANY PISTON WHICH IS NOT WORKING, CHECK THE ELECTRIC CONNECTIONS



2

1	2	3	4	5	6	7	8	9	10	11	12	13	14	15	16
17	18	19	20	21	22	23	24	25	26	27	28	29	30	31	32

ADIM SAYISI

KAYIT NO

KAYDET

OKU

DÖNDÜR

0
0

SİL

DUR-GİT

0
0

DESEN ÇİZ

GERİ-GİT

0
0

MENÜ

AIR PROBLEMS

THE PRESSURE CONTROLLER SHOULD NOT BE LESS THAN 6 BAR PRESSURE

THE MINIMUM PRESSURE LEVEL OF YOUR AIR COMPRESSOR SHOULD BE 6.5 BAR.

